

Colloid-Facilitated Transport: Studies Related to CFM Project at GTS

U.S. Nuclear Waste Technical Review Board Spring Meeting
Feb 26, 2019
Las Vegas, Nevada

Hakim Boukhalfa, Los Alamos National Laboratory
Paul Reimus, Los Alamos National Laboratory (Retired)

Colloid-Facilitated Transport Team

Los Alamos National Laboratory

Katherine Telfeyan, Paul W. Reimus, Hakim Boukhalfa,
S. Doug Ware



Sandia National Laboratories

Wang, Yifeng



Lawrence Livermore National Laboratory (LLNL)

Mavrik Zavarin



Department of Energy*

Jay Jones, Prasad Nair

*During the time of formal DOE participation in CFM Project (2013-2015)

Colloid-Facilitated Transport (CFT) of Radionuclides

Colloids

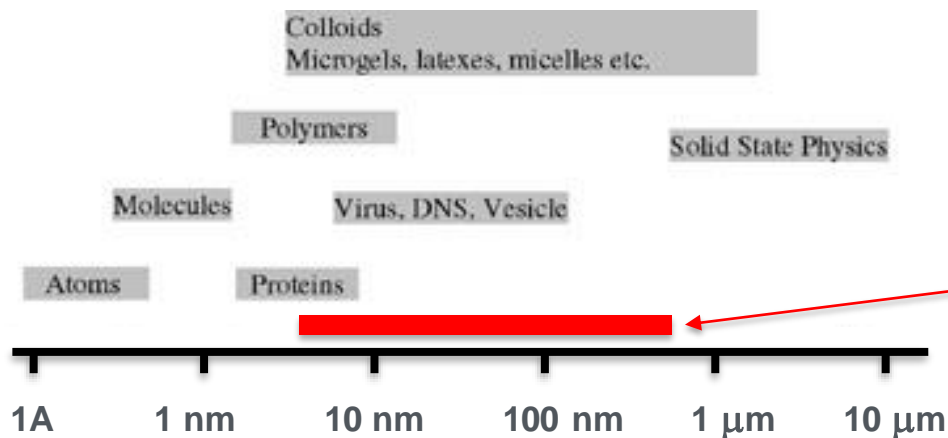

Colloid-Facilitated Transport of Solutes

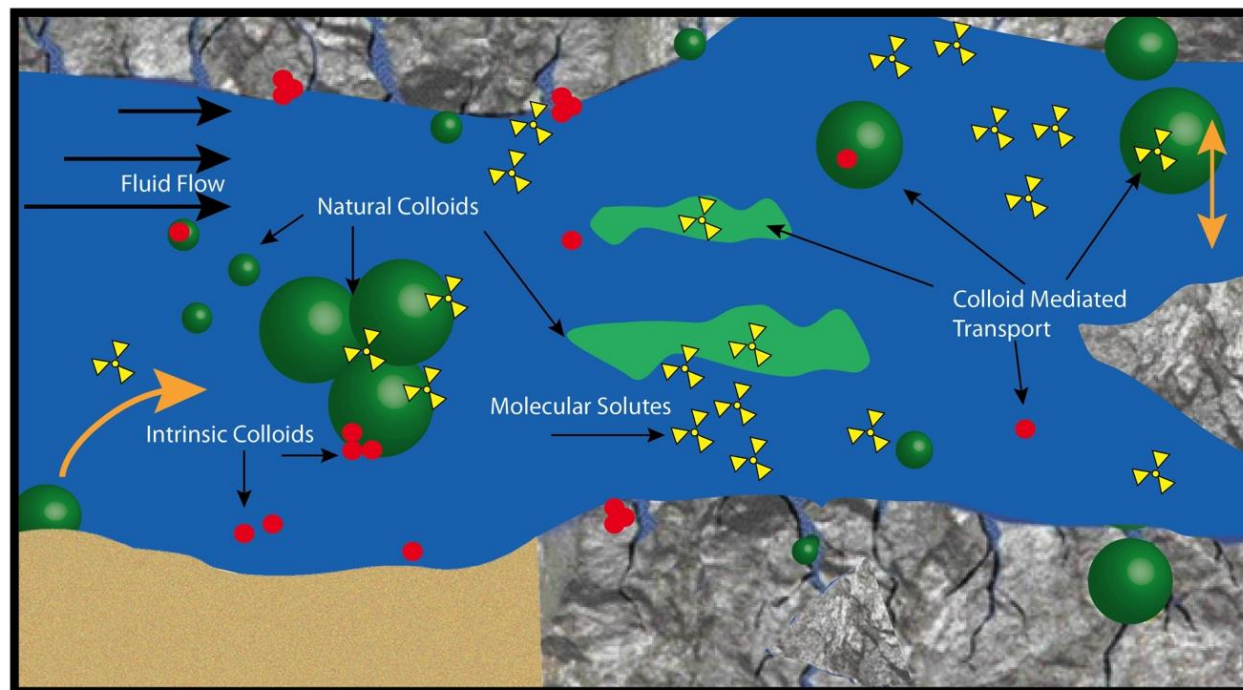

International URL Portfolio in a Nutshell

- Key R&D Issues**
- Near-Field Perturbation
 - Engineered Barrier Integrity
 - Flow and Radionuclide Transport
 - Demonstration of Integrated System Behavior

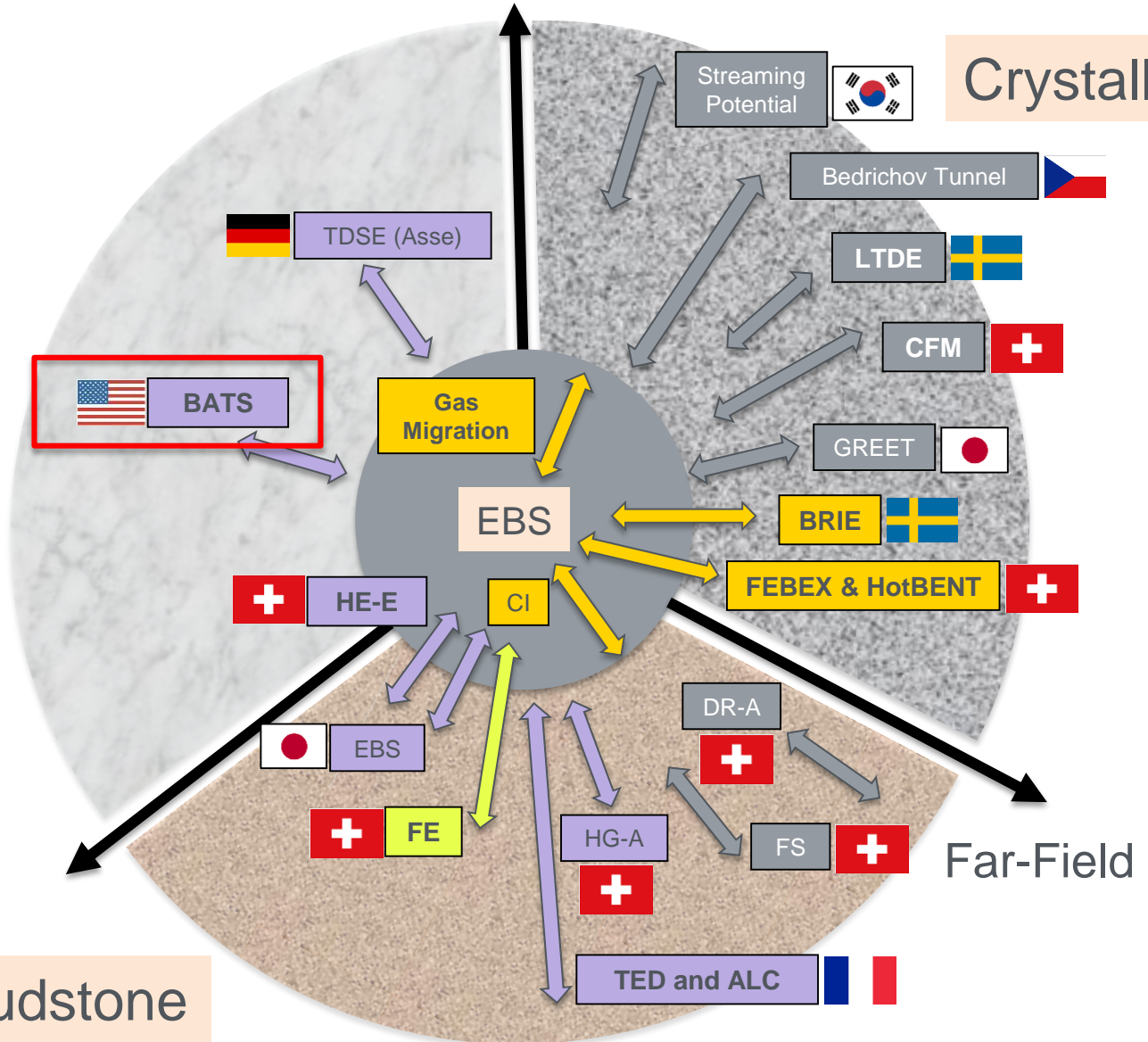

Argillite/Mudstone

The "CFT Ladder"

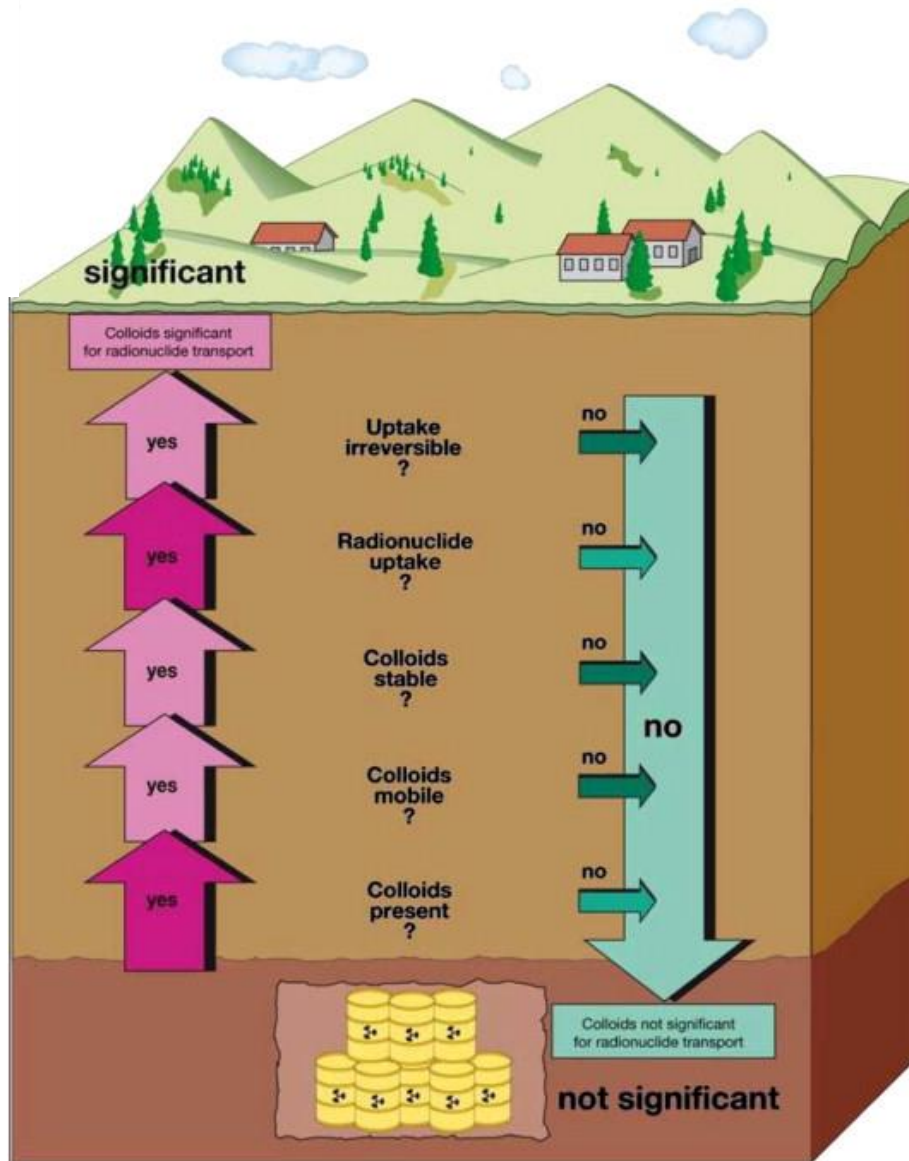

In Words:

For CFT to be a problem, you need stable colloids that are capable of migrating long distances, AND you need radionuclides to be very strongly associated with these colloids

CFM (Colloids Formation and Migration) Project Overview

Structure of the CFM Project

Laboratory studies

Colloid-Rn interaction
Colloid Generation
Field test analysis

- Colloid generation
- Colloid transport/retardation and stability
- Radionuclide association
- Bentonite intercomparison (MX-80, Febex, Kunigel)

Field experiments

In situ test: formation & Migration tests with colloids, homologues, Rn tracers

- Site characterization and site preparation
- Assessing the advective travel times
- Analyzing the recovered tracer mass
- Estimating dispersion parameters in the shear zone flow fields

Modelling studies

Solute, colloid and associated Rn transport
Colloid generation

- Supporting the in-situ tests
- Initiating performance-assessment relevant studies on colloid generation and on colloid-facilitated radionuclide transport

The Grimsel Test Site Underground Facilities

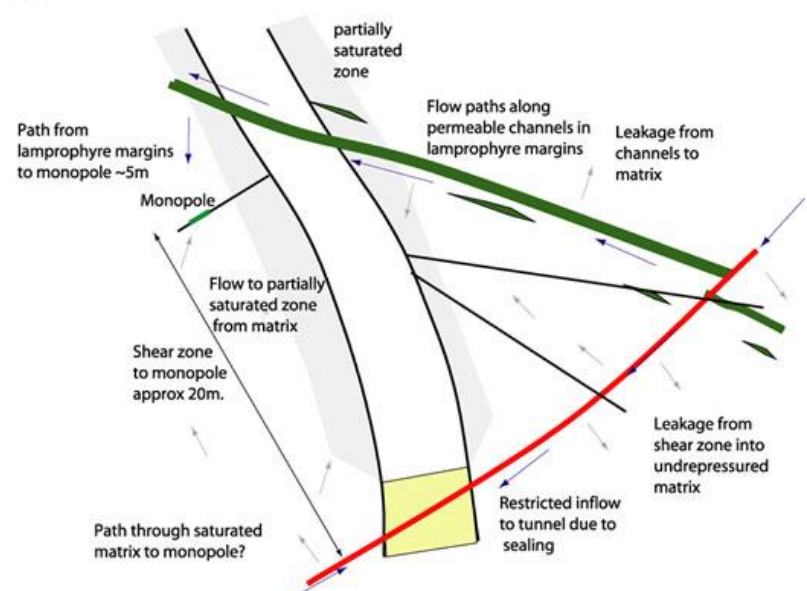
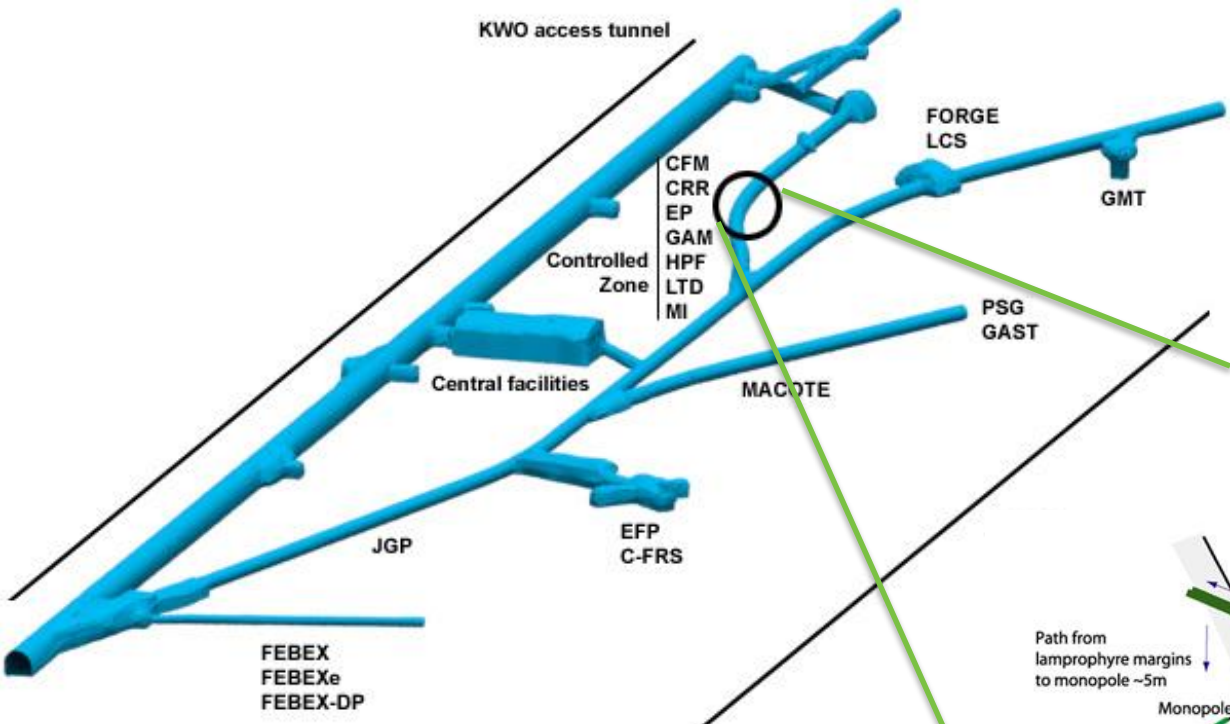

CFM in-situ experiment

CFM (Colloids Formation and Migration) Project Overview

- CFM began in 2004 (preceded by CRR, Colloid and Radionuclide Retardation Project, 1998-2003)
- U.S. was formal partner in 2013-2015, with informal involvement since 2006
- Focus has always been on bentonite colloids in fractured crystalline media (a granodiorite at GTS)
 - Relevant Scenario: Waste package breach allows radionuclides to sorb onto bentonite backfill, which subsequently erodes into flowing fractures, carrying radionuclides away on colloids
- Distance Scales: ~2 – 6 meters
- Time Scales: 1 – 60 hours (mean residence times), with general progression of increasing time scales
- RN-doped bentonite plug emplacement in 2015

Relevant scenario for bentonite colloids in fractured crystalline media

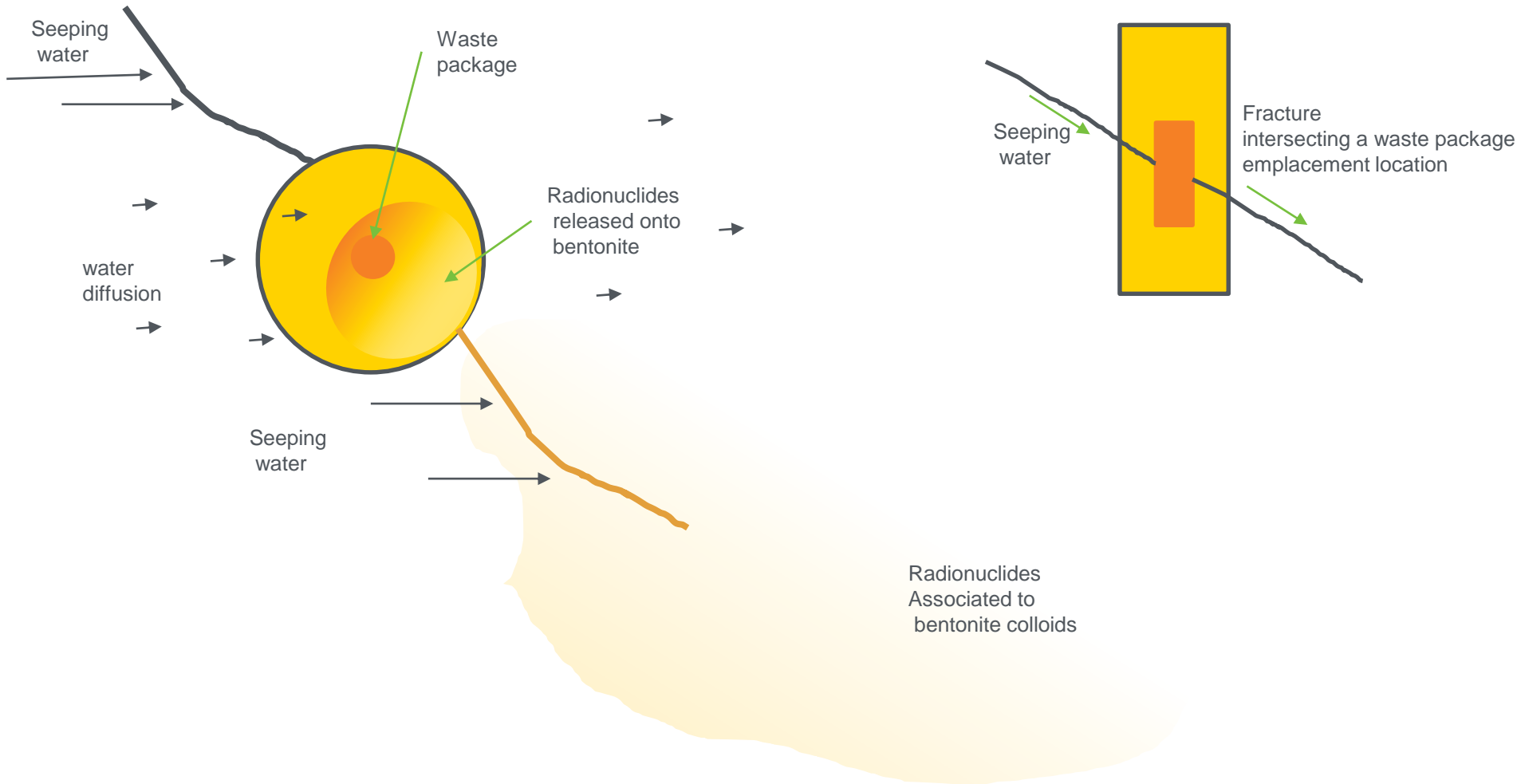

Cartoon showing how a waste package breach allows radionuclides to sorb onto bentonite backfill, which subsequently erodes into flowing fractures, carrying radionuclides away on colloids

CFM Project Testbed

Hydraulic Isolation and Control of Shear Zone Inflow via 3.5-m Diameter “Packer”

Plan View of Testing Area

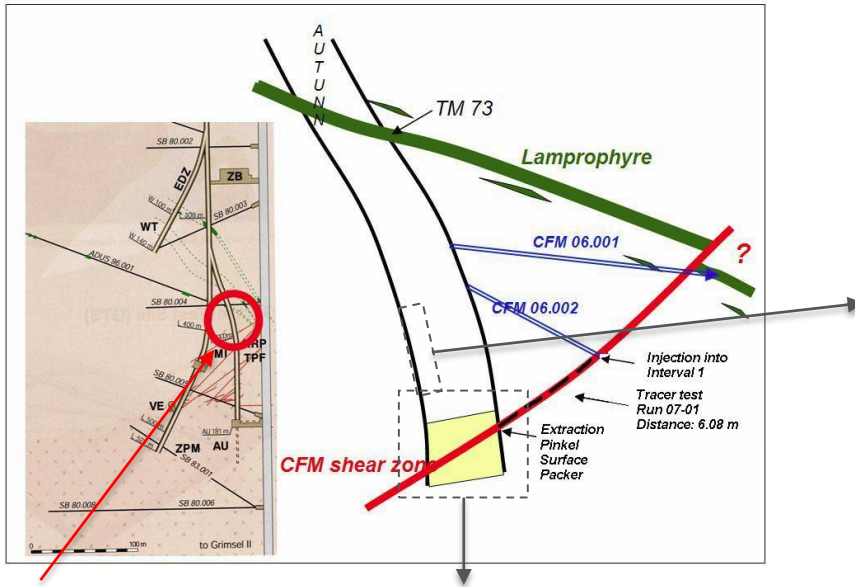

Testing Control and Data Acquisition System

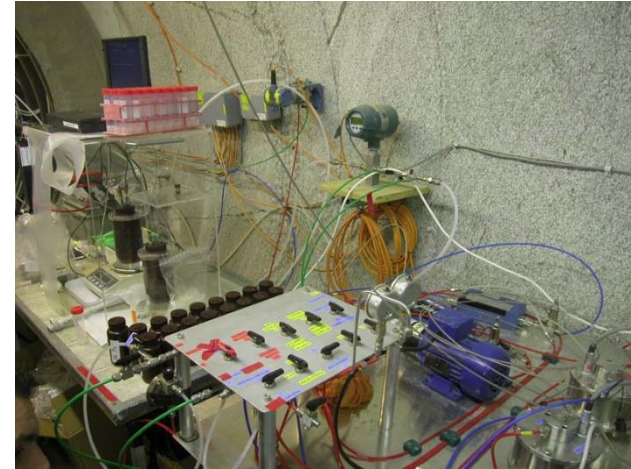

Radiological
Control Area

Pinkel Surface Packer



Surface Packer Schematic

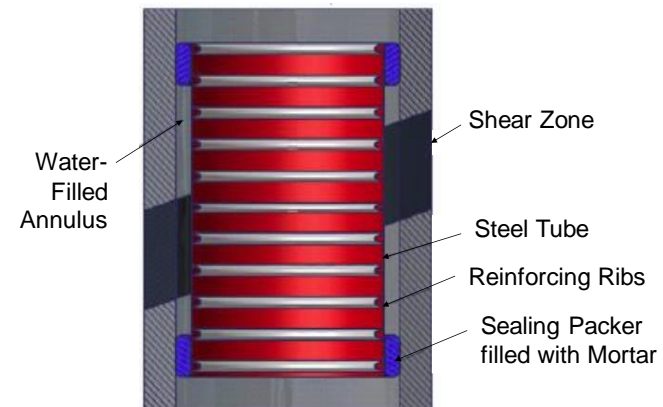

Colloid-Facilitated Transport Tests (2002-2013)

6 CFT Tests: 3 with tri- and tetravalent “homologues”, and 3 with radionuclides (also one radionuclide test without colloids, CRR 31)

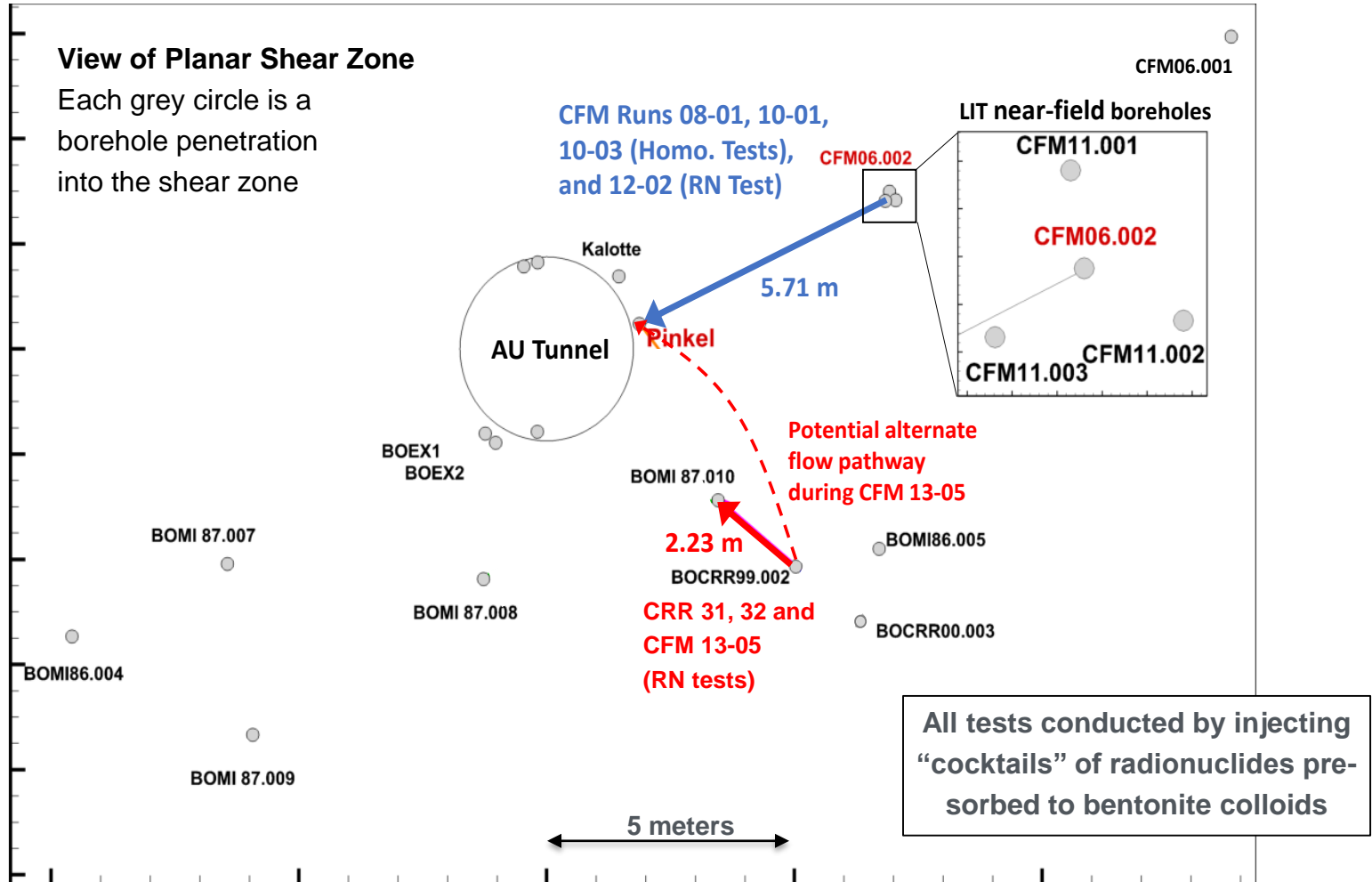

Example of Model Interpretations (CFM Test 12-02)

Modeling Approach:

- Model Conservative Tracer First (Amino-G Acid, or AGA)
- Then Model Colloids Using Filtration Parameters Coupled with Conservative Transport
 - Account for lower colloid recovery relative to conservative tracer by filtration processes
- Then Model Radionuclides using Sorption/Desorption Parameters Coupled with Colloid Transport
 - Account for lower radionuclide recovery relative to colloids by RN desorption from colloids

Conservative Tracer (AGA), Colloids, and Selected Radionuclides

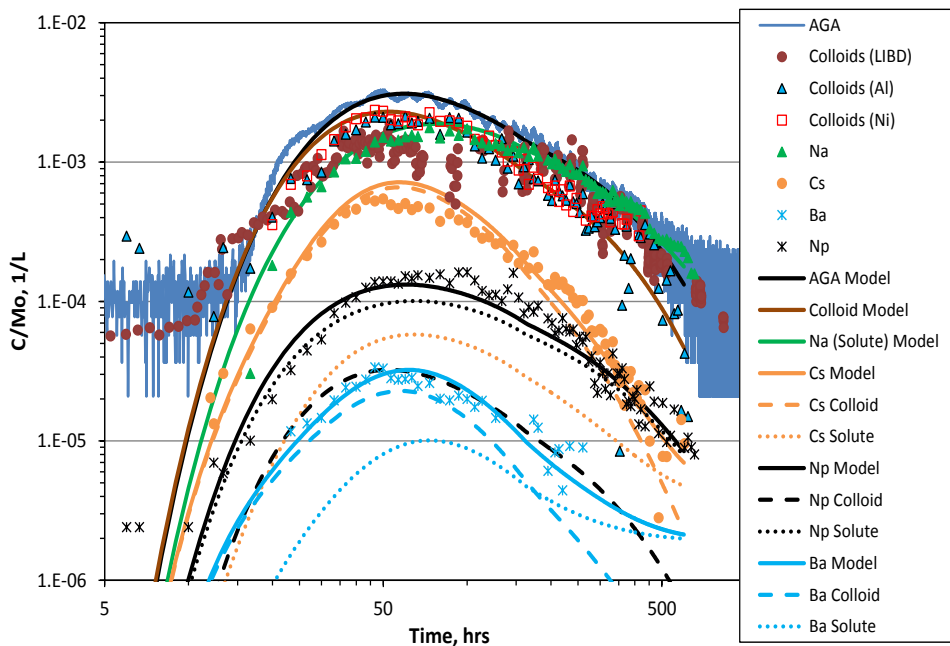

Colloids, Pu, and Am

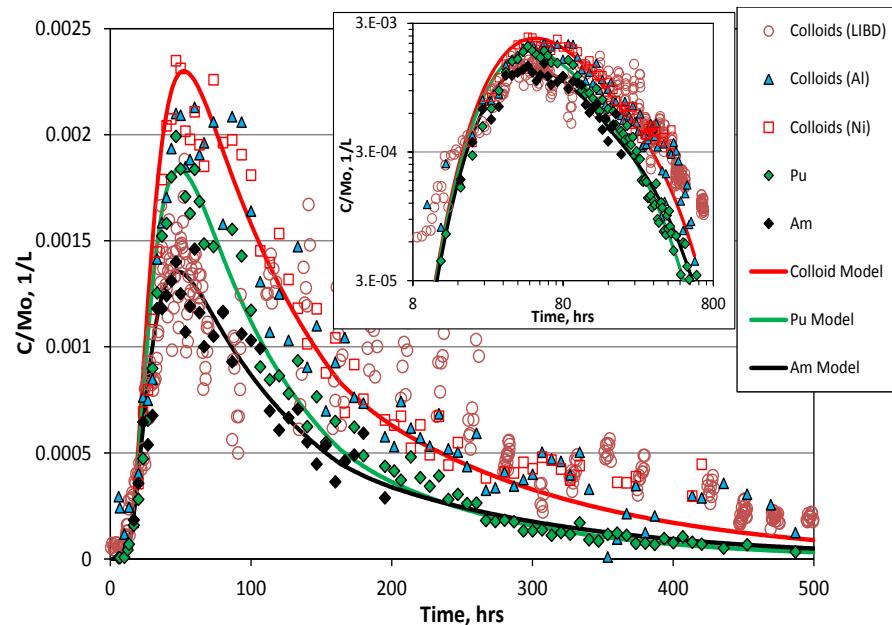

Summary of 2002-2013 Results

Bentonite Colloid Filtration Rate Constants

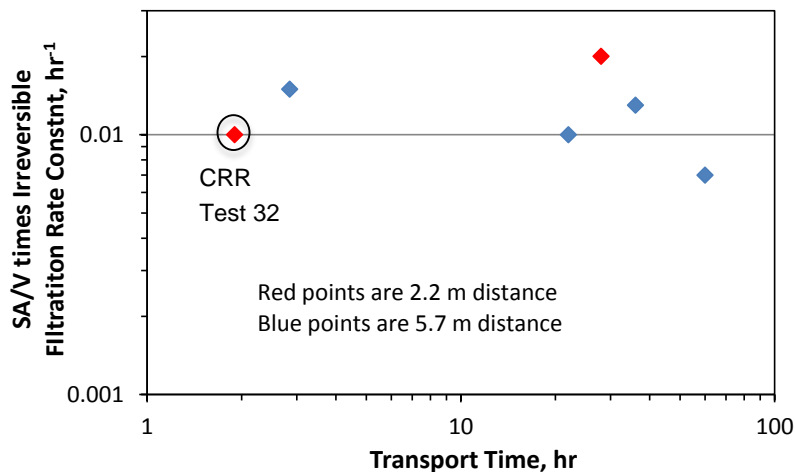

Colloid Recoveries

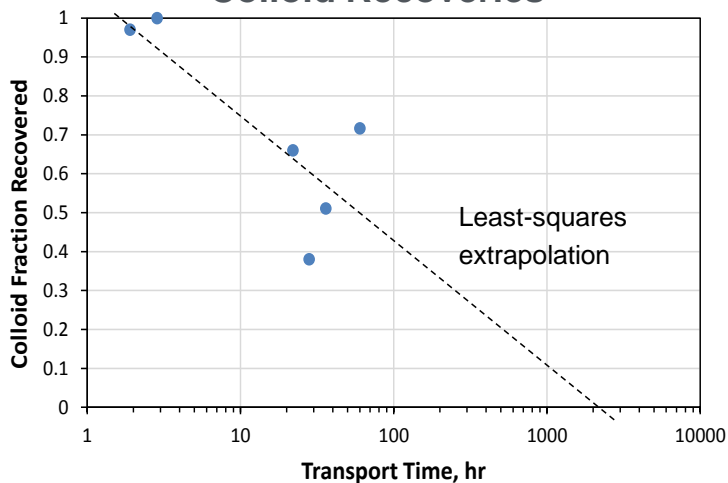

RN/Homologue Desorption Rate Constants

Trivalents and Cesium

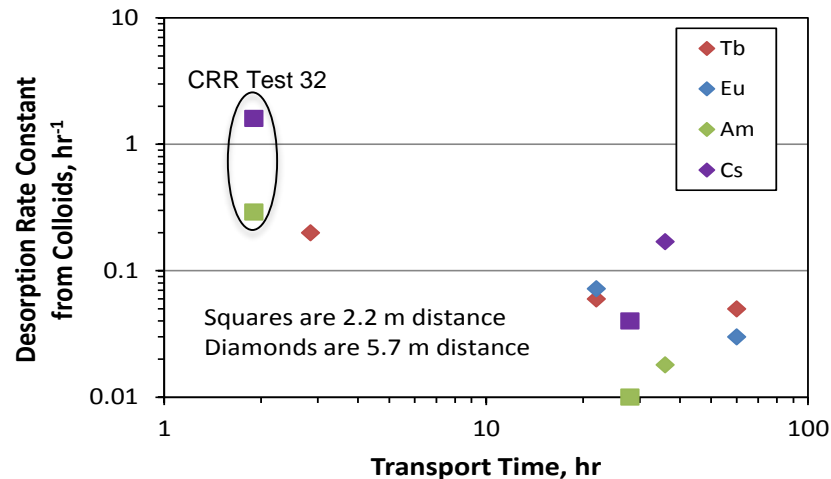

Tetravalents

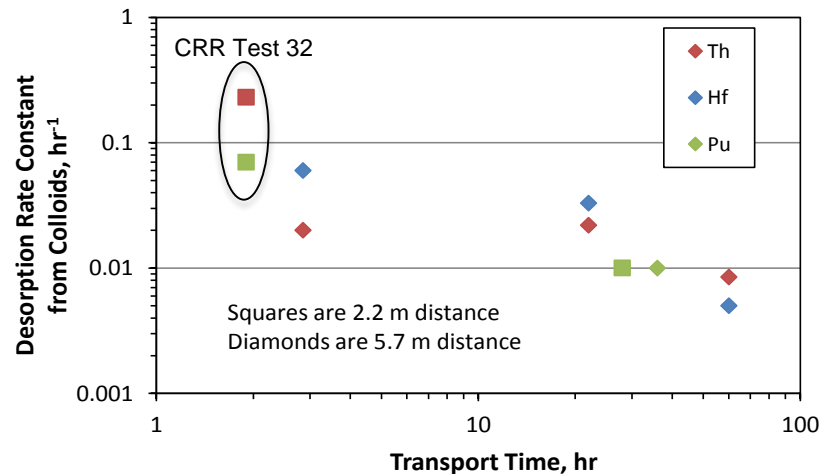

Upscaling Questions

Can a Simple Extrapolation be Applied?

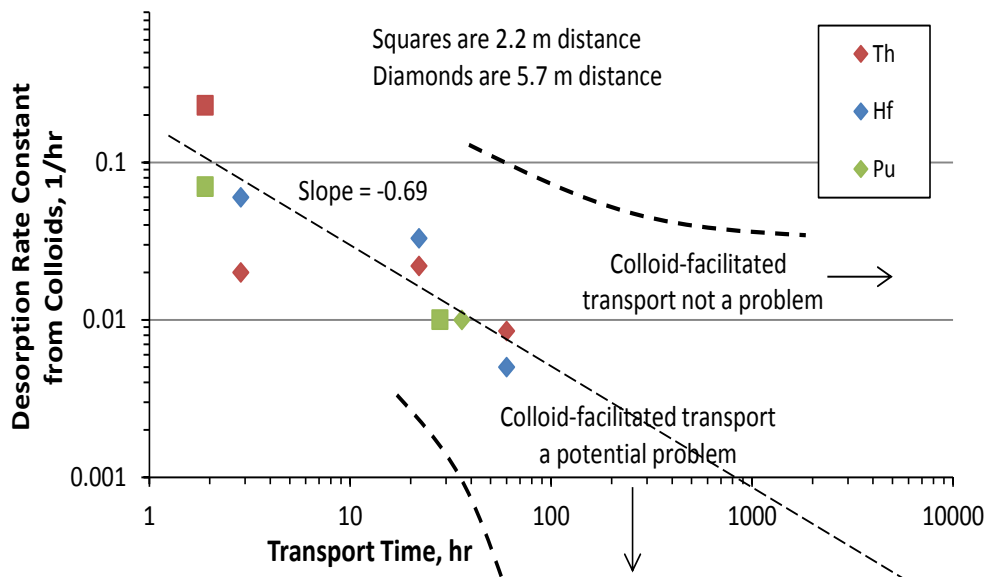

This plot is not interpreted as a literal decrease in desorption rate constants with increasing time scale, but rather as a revelation of stronger and stronger sorption sites (with smaller desorption rate constants) as time scales increase.

The key question is: Are there any sorption sites with slow enough desorption rates to be effectively irreversible over repository time and distance scales?

And if so, are there any colloids that will remain mobile over these time/distance scales?

Recent Approach in Lab Testing: Cs Associated with NNSS Colloids

Repeat Injections of Cavity Water (~48-hr Residence Time)

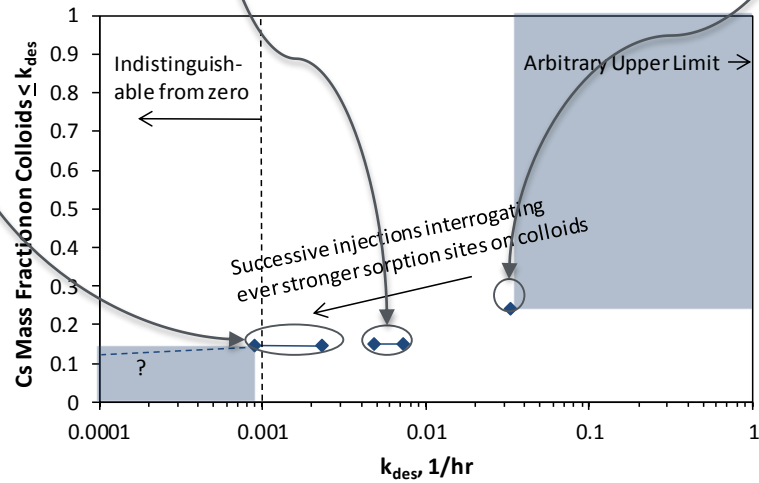
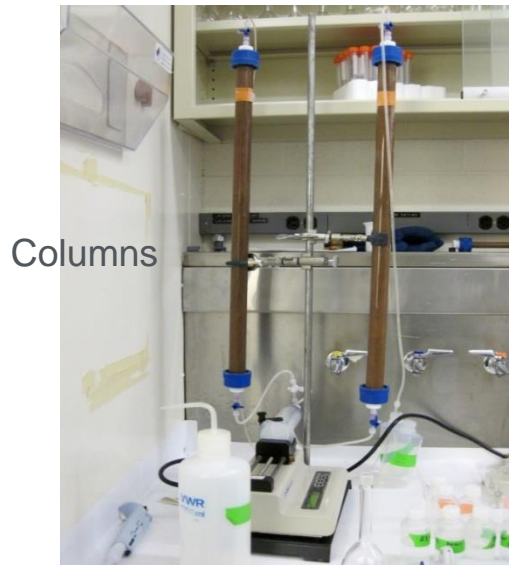
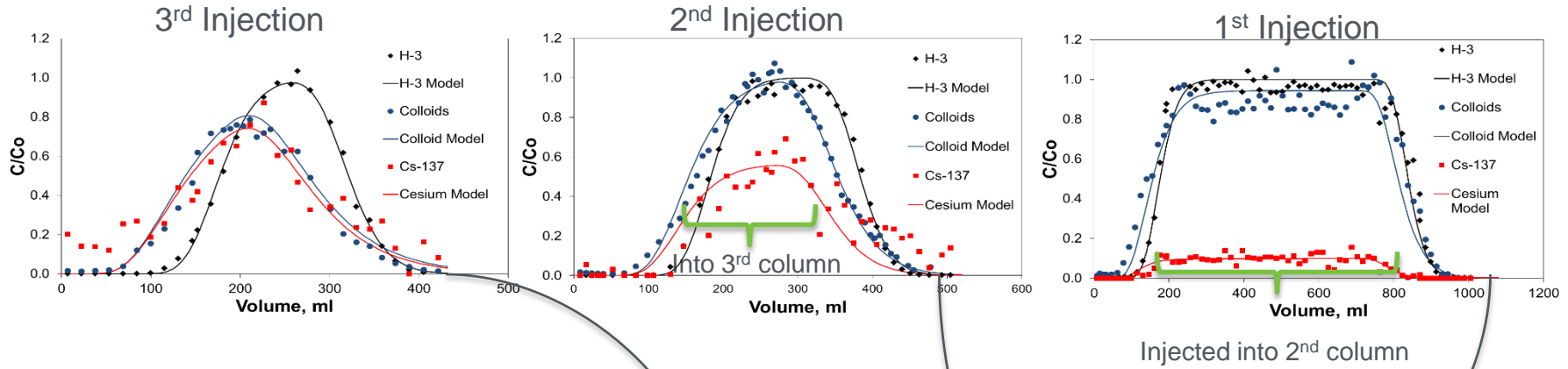

Each successive injection interrogates stronger Cs sorption sites on colloids

CFM and the “CFT Ladder”

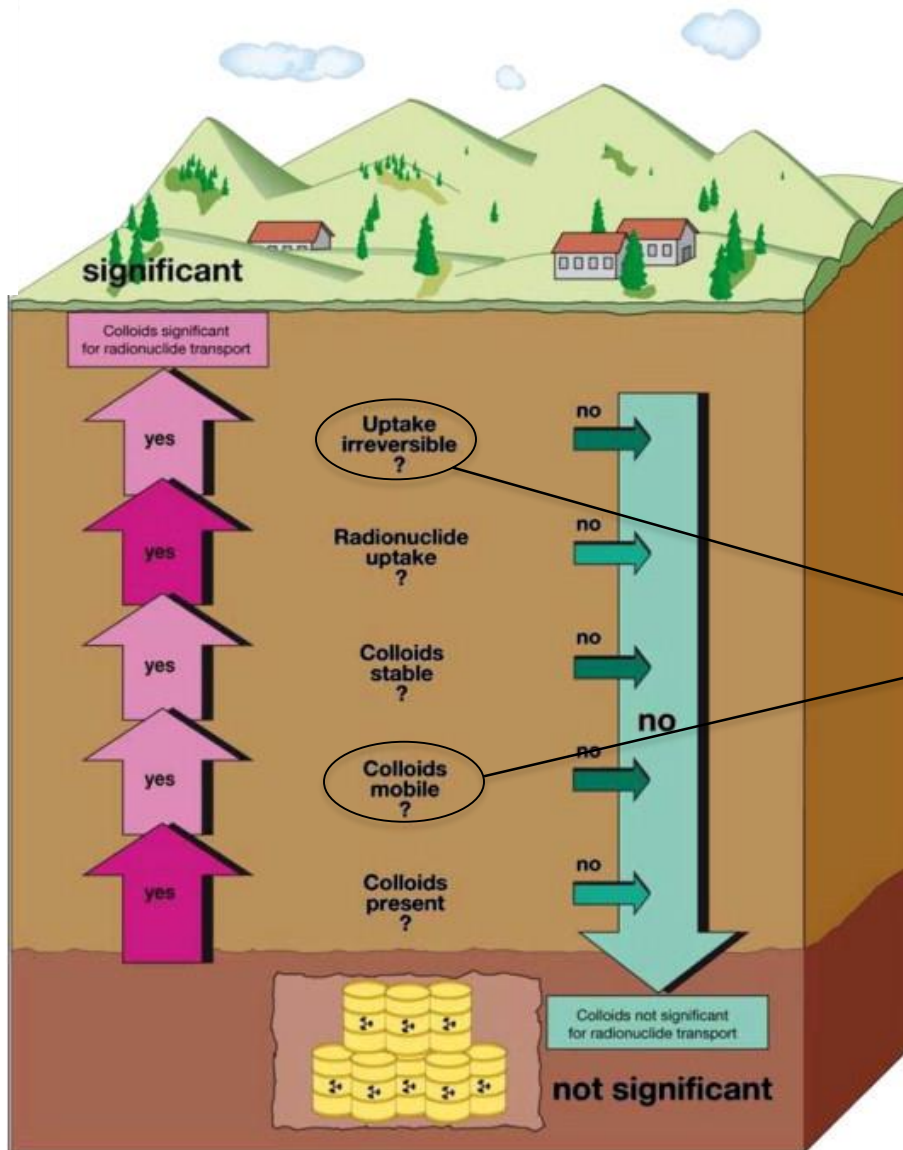

CFM answers:

Yes, for up to 100 hrs and 6 meters in case of bentonite colloids in groundwater with ~0.7 mM ionic strength, but extrapolation to longer time and distance scales is a big uncertainty

CFM Long-Term In-Situ Test (LIT): 2015-present

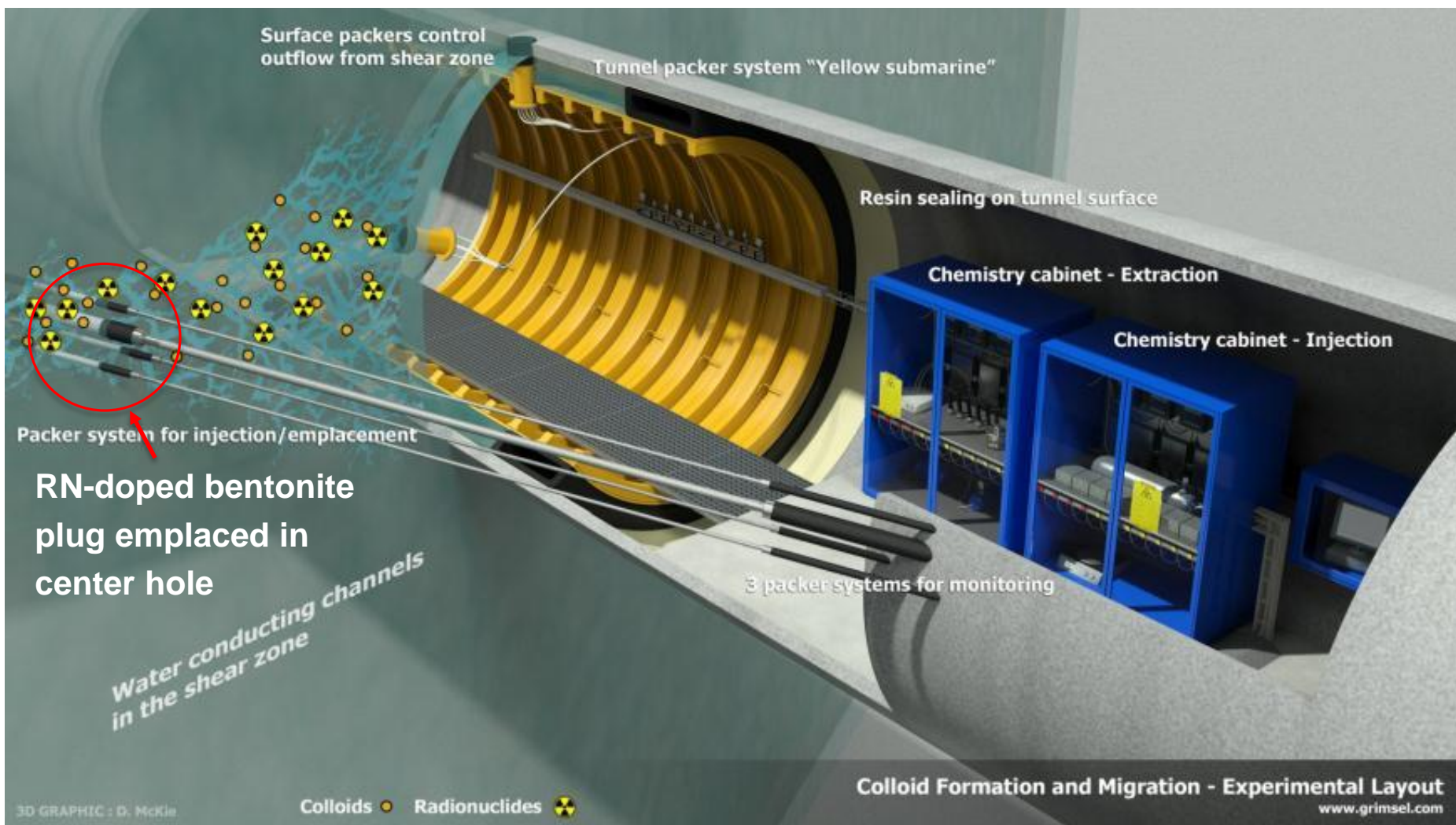

Shear-zone flow kept the same as in CFM 12-02 test

RN-doped bentonite emplacement details

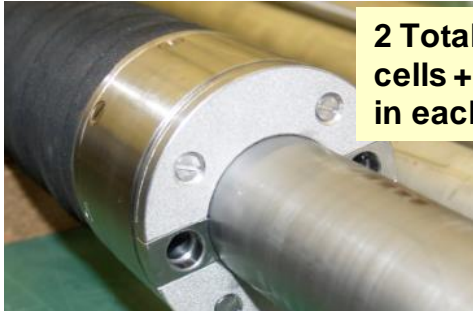

2 Total Pressure cells + piezometer in each packer face



Precompact rings of FEBEX bentonite:

- Outer diameter: 82mm
- Inner diameter: 43mm
- Dry density: 1.65Mg/m³
- Gravimetric water content: ~14%

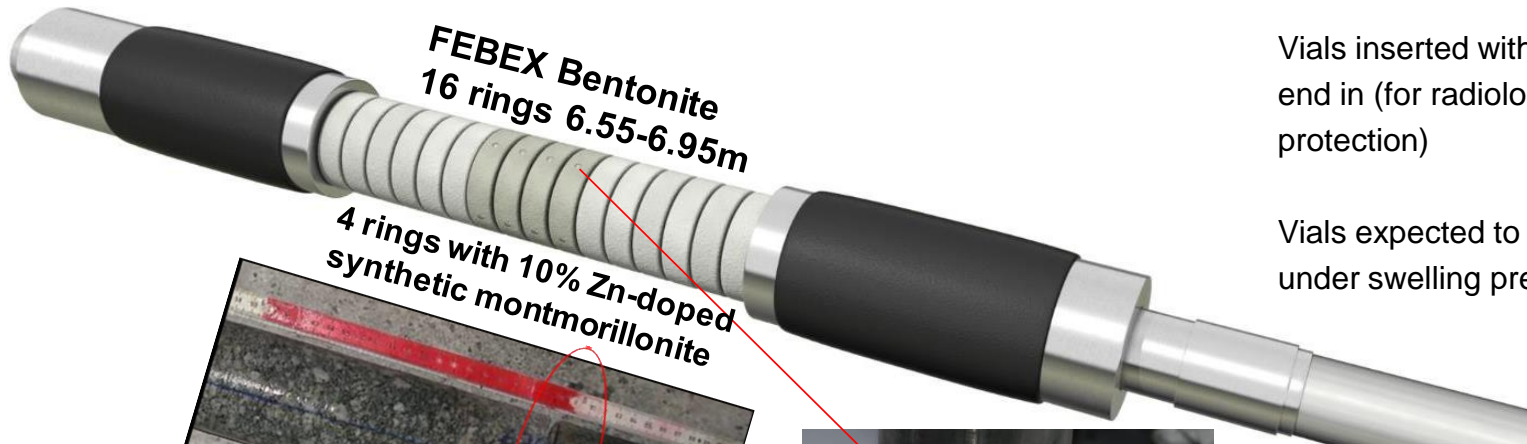

Vials inserted with open end in (for radiological protection)

Vials expected to break under swelling pressure

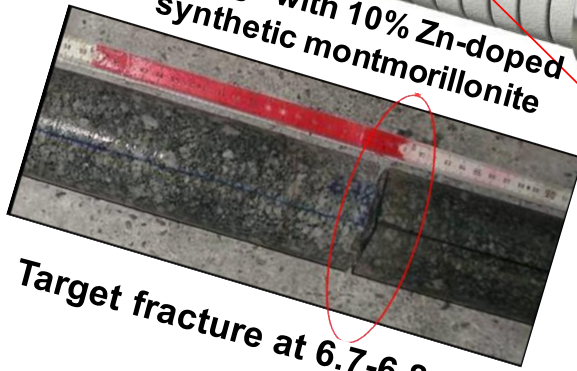

Target fracture at 6.7-6.8m



Tracers in glass vials:
Ni-doped synthetic montmorillonite, AGA and RN:Ca-45, Se-75, Tc-99, Cs-137, U-233, Am-241, Pu-242, Np-237

16 Vials

CFM Long-Term In-Situ Test (LIT): 2015-present

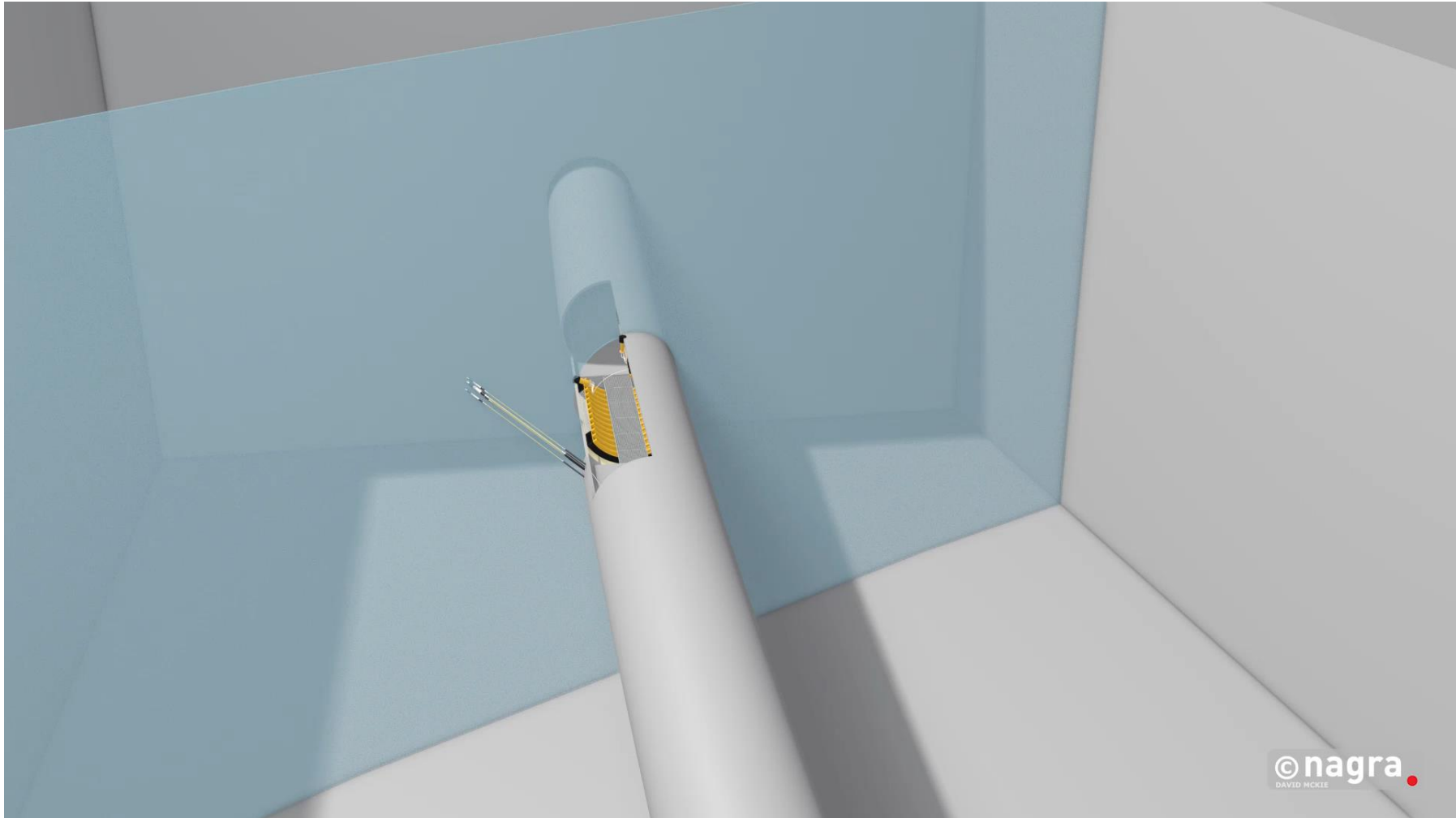

First ~400 days of monitoring in near-field boreholes

Bentonite saturated and swelled very quickly

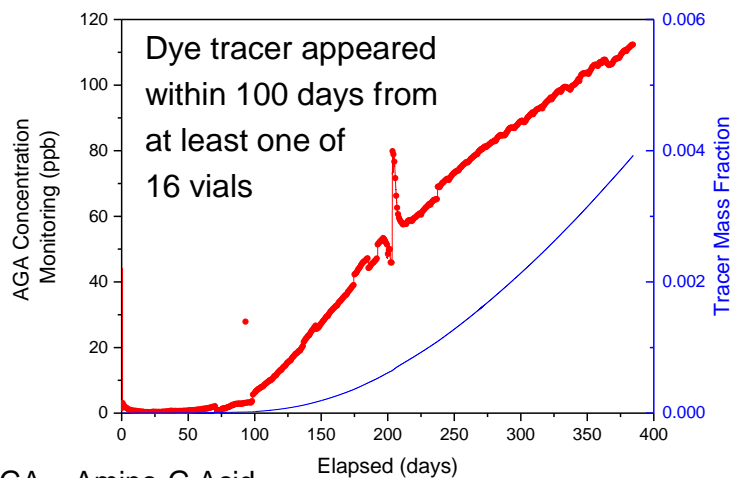
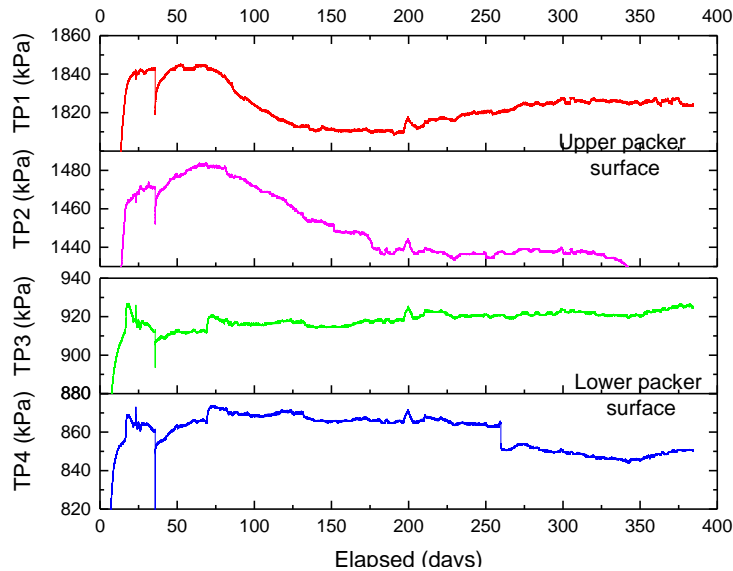

AGA = Amino-G Acid

Overcoring (excavation) initiated in December 2018

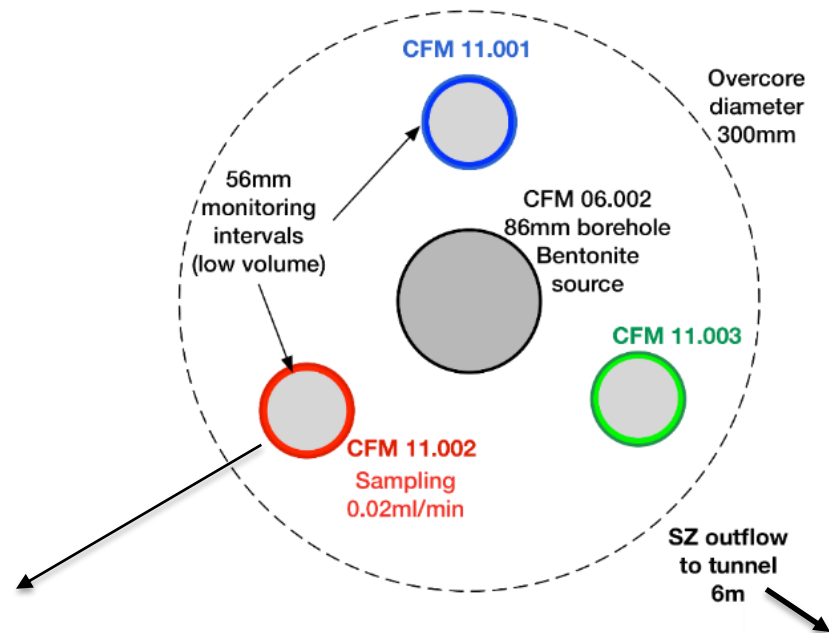

Longer-Term (~4-yr) Results

- Only conservative tracer and minor colloid breakthroughs in monitoring holes (6-7 cm away)
- However, very small concentrations (ppq) of ^{99}Tc are being detected by AMS in monitoring hole
- Almost imperceptible concentrations of conservative tracer and colloids at tunnel wall (~6 m away)
- No actinides detected anywhere

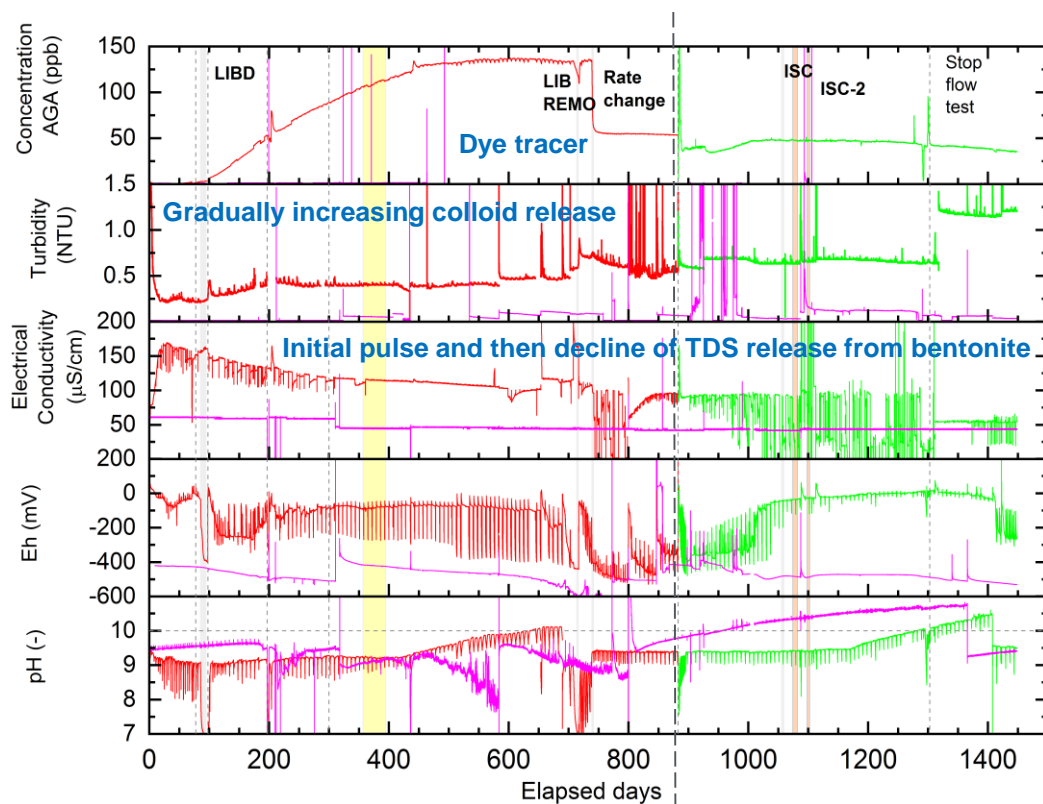

Switch from red to green monitoring hole (882 days)

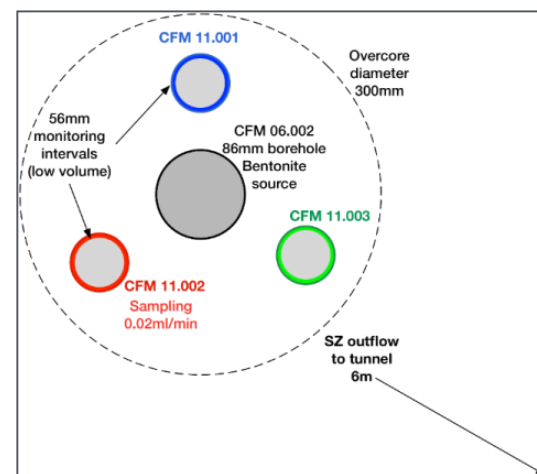

More detailed information expected from overcoring and post-mortem

Summary of Knowledge Gained from CFM Participation

- Insights have been gained as to how to obtain defensible answers to predict radionuclide transport in fractured granites. State of the art knowledge on Colloid-Facilitated Radionuclide Transport and colloid facilitated transport and a mathematical formulation and test cases have been described in two reports:
 - Colloid-Facilitated Radionuclide Transport: Current State of Knowledge from a Nuclear Waste
 - Repository Risk Assessment Perspective, *FCRD-UFD-2016-000446*, August 2016.
- Site specific studies still need to be performed to gain confidence in the prediction
- The CFT ladder should be applied to evaluate the potential for enhanced transport with colloids, but most indications are that only very small fractions of strongly-sorbing radionuclides will be capable of CFT over repository time and distance scales

Summary of Knowledge Gained from CFM Participation

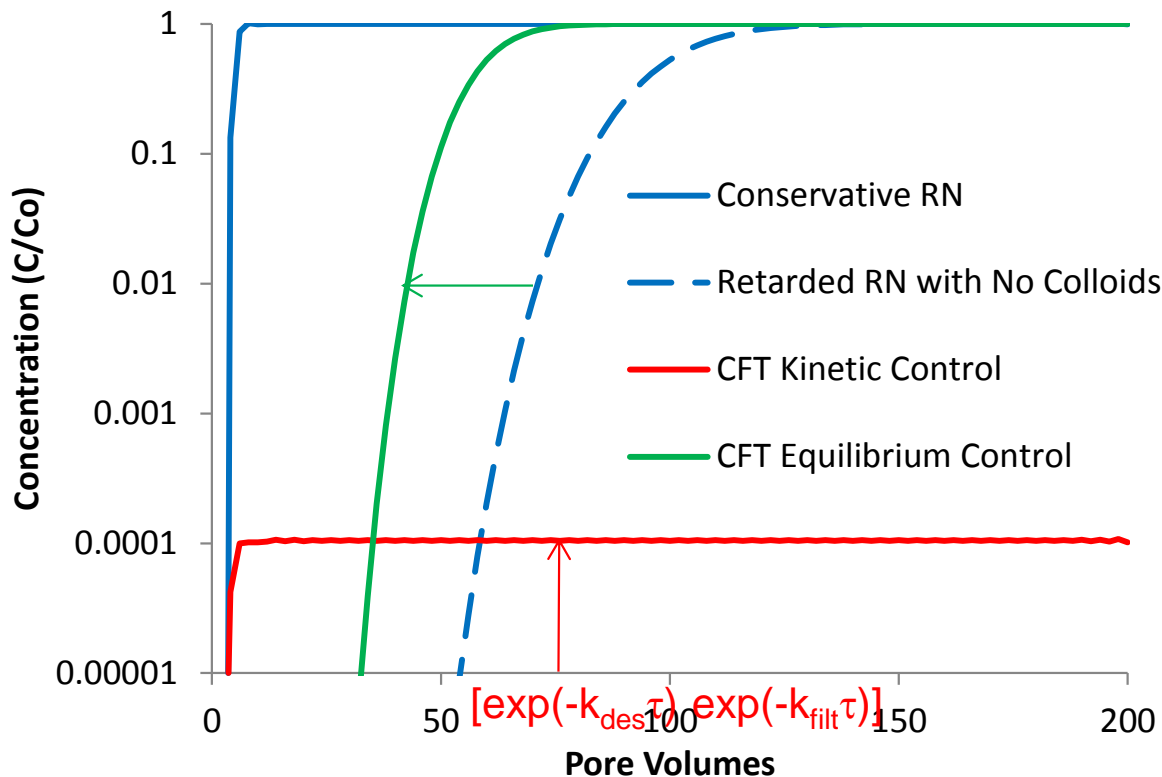

Retardation factor without colloids

$$R_{eff} = \frac{1 + \frac{\rho_B}{\phi} K_d + K_{d,col} C_{col}}{1 + K_{d,col} C_{col}}$$

- CFT requires very slow desorption from colloids AND very slow filtration of the RN-bearing colloids (relative to time scales of interest)
- Intuitively, one might expect that stable colloids generated from waste-form degradation that have radionuclides incorporated into their structure (as opposed to a sorption association) might pose the biggest risk

Questions?

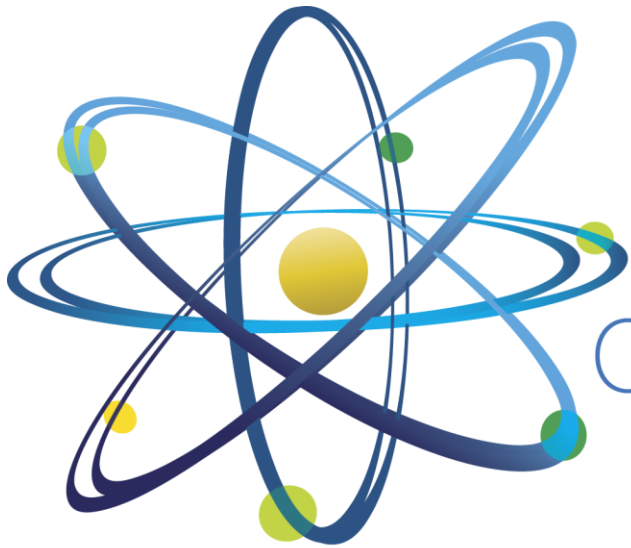

Clean. **Reliable. Nuclear.**

Abbreviations

CRR: Colloid and Radionuclide Retardation Experiment

GTS: Grimsel Test Site

CFM: Colloids Formation and Migration

CFT: Colloid Facilitated transport

CFT Ladder: Colloid Facilitated transport ladder

URL: Under Ground Laboratory

AGA: Amino-G Acid

LIT: Long-Term In-Situ Test