

Horizontal Dry Cask Simulator Testing and Applications to Blind Model Validation

Sam Durbin, Ramon Pulido, Eric Lindgren, and Alex Salazar
Sandia National Laboratories

Nuclear Waste Technical Review Board
Alexandria, VA

November 19, 2019

HDCS Overview and Construction

Horizontal Dry Cask Simulator (HDACS) Overview

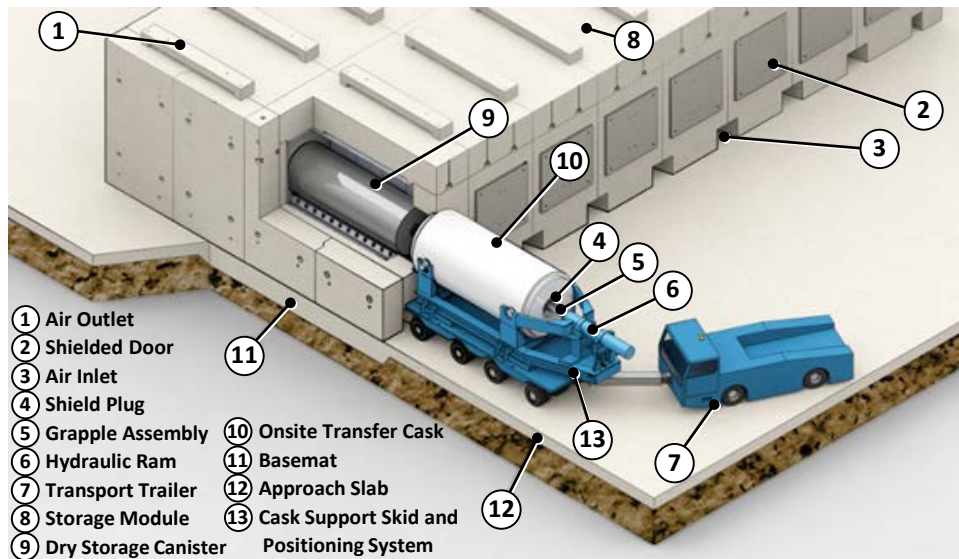

Source: <http://us.aveva.com/EN/home-3138/aveva-nuclear-materials-tn-americas--nuhoms-used-fuel-storage-system.html#tab=tab6>

- Purpose: Validate assumptions in computational thermal-hydraulic modeling for spent fuel cask thermal design analyses
 - Used to determine steady-state cladding temperatures in dry casks
 - Needed to evaluate cladding integrity throughout storage cycle
- Measure temperature profiles for a wide range of decay power and helium cask pressures
 - Mimic conditions for horizontal dry cask systems with canisters
 - Simplified geometry with well-controlled boundary conditions
 - Provide measure of mass flow rates and temperatures throughout system
- Use existing prototypic BWR Incoloy-clad test assembly
 - Electrically-heated fuel simulators

Horizontal Dry Cask Simulator (HDCS) Overview

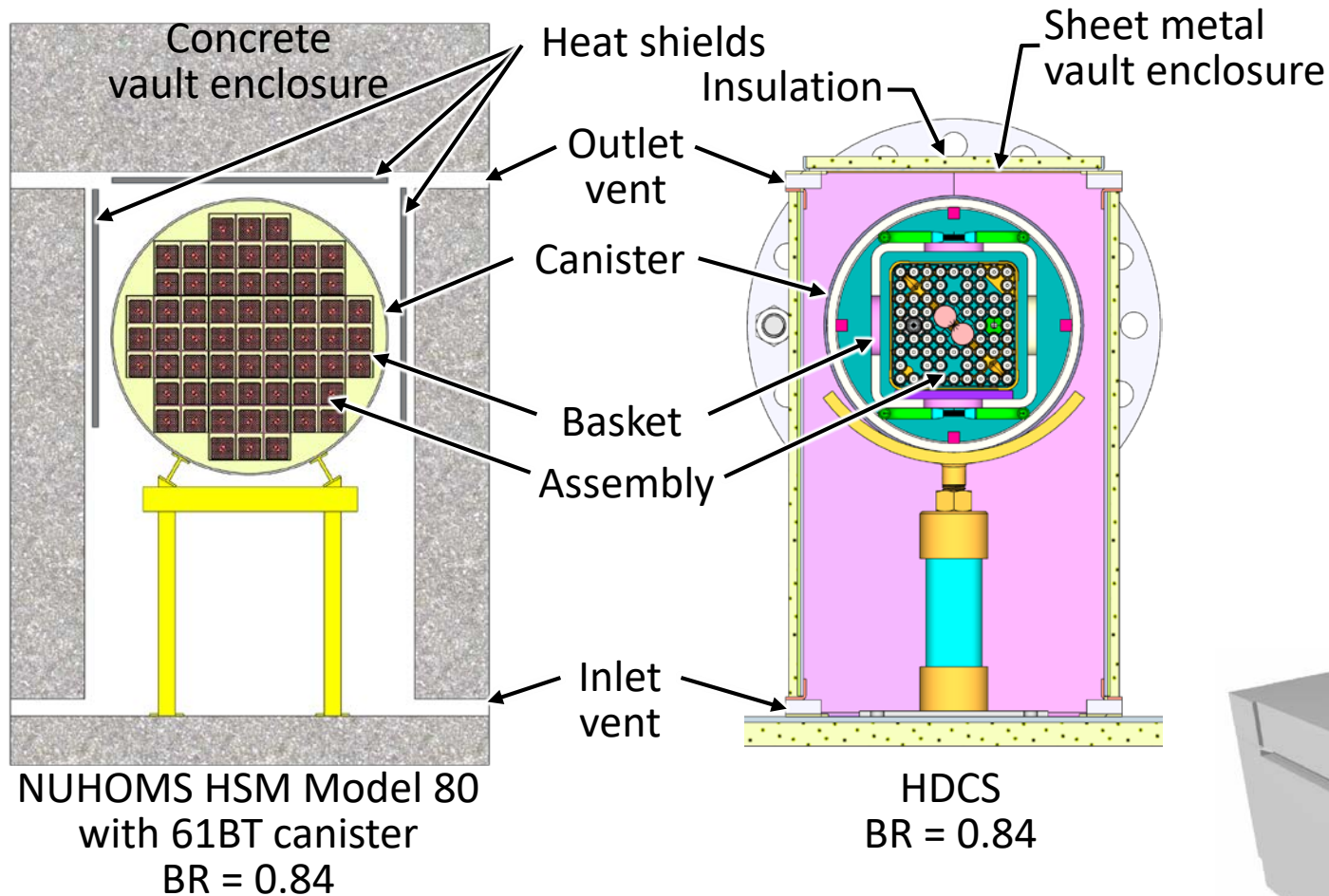

- Repeat vertical dry cask simulator (DCS) testing for horizontal storage configuration
 - Wide range of test parameters
 - Decay heats, gas backfills, and internal pressures
 - Collect validation data
 - Temperatures and air mass flow rates

Depictions of horizontal storage modules

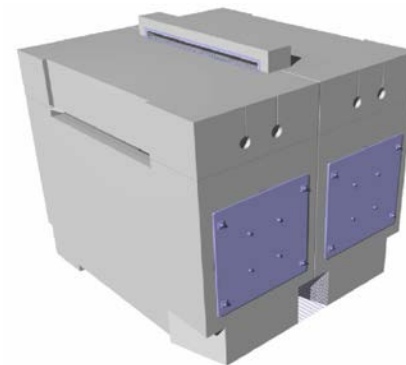

Source: http://us.aveva.com/home/liblocal/docs/Catalog/AREVA-TN/ANP_U_299_V5_17_ENG_NUHOMS_HSM.pdf

Prototypic Assembly Hardware

Upper tie plate

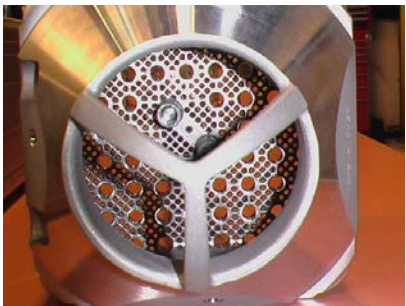
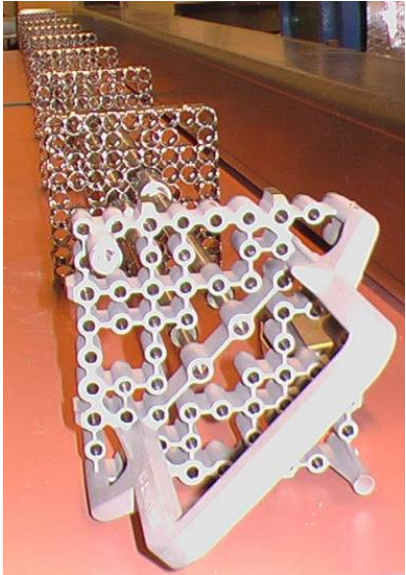

Nose piece and debris catcher

BWR channel, water tubes and spacers

- Most common 9×9 BWR fuel in US
- Prototypic 9×9 BWR hardware
 - Full length, prototypic 9×9 BWR components
 - Electric heater rods with Incoloy cladding
 - 74 fuel rods
 - 8 of these are partial length
 - Partial length rods run 2/3 the length of assembly
 - 2 water rods
 - 7 spacers

Thermocouple (TC) attached directly to cladding

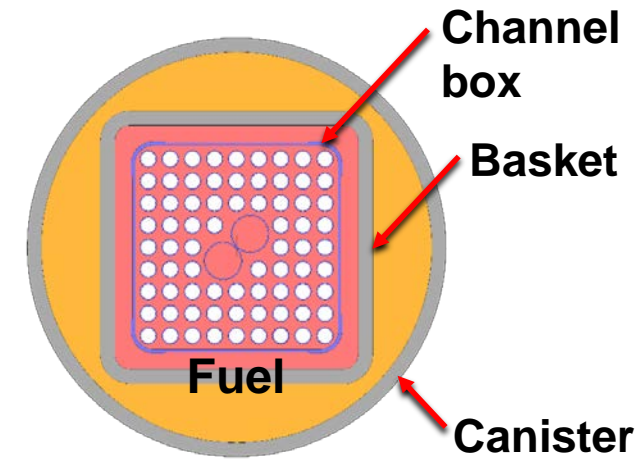
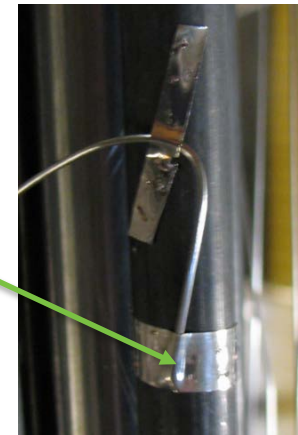

Pressure Vessel Hardware

- Scaled components with instrumentation well
- Coated with ultra-high-temperature paint

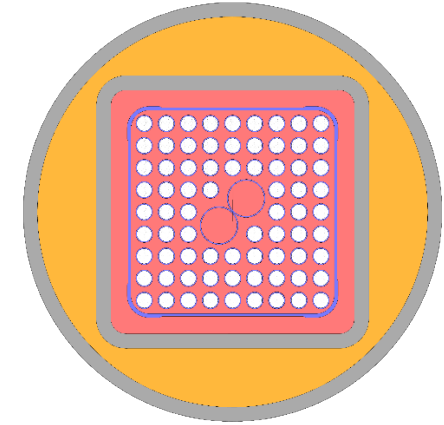
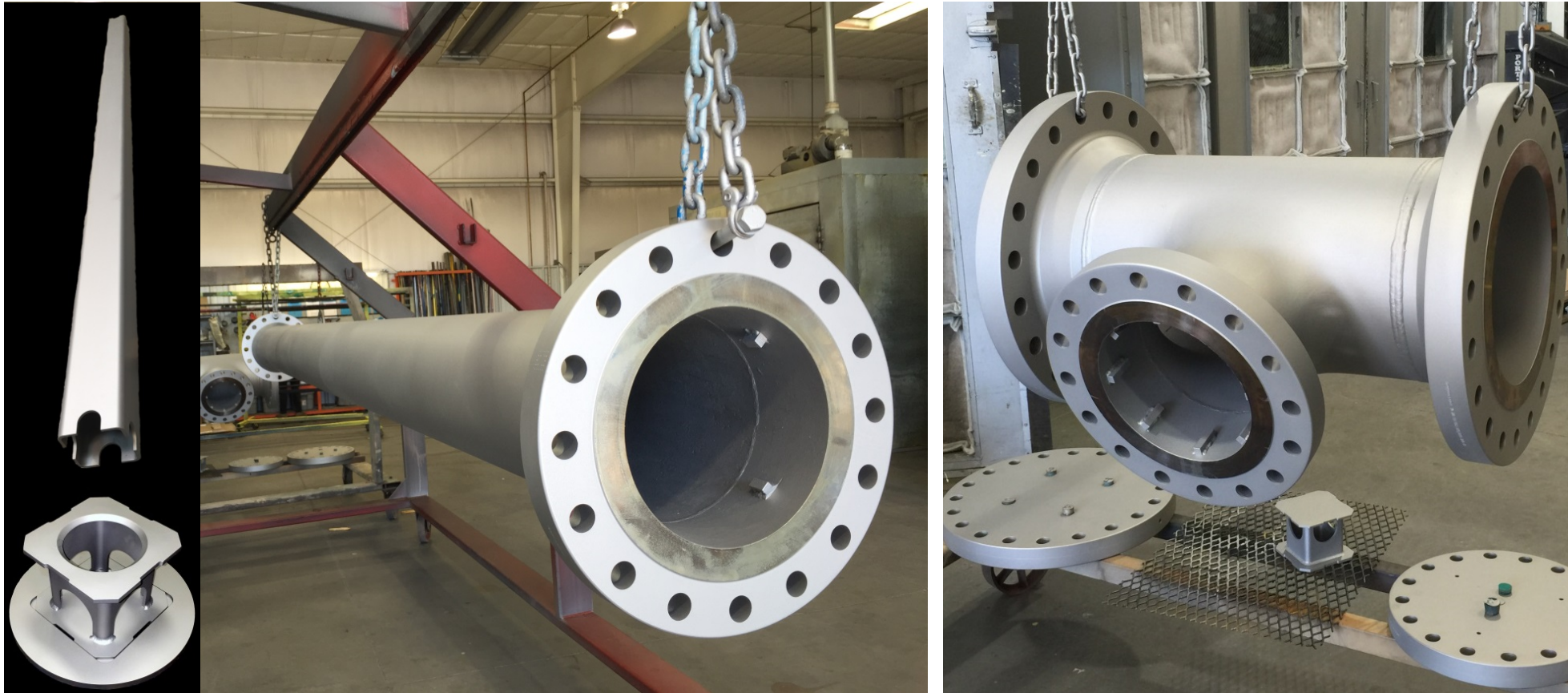

Assembly Modifications

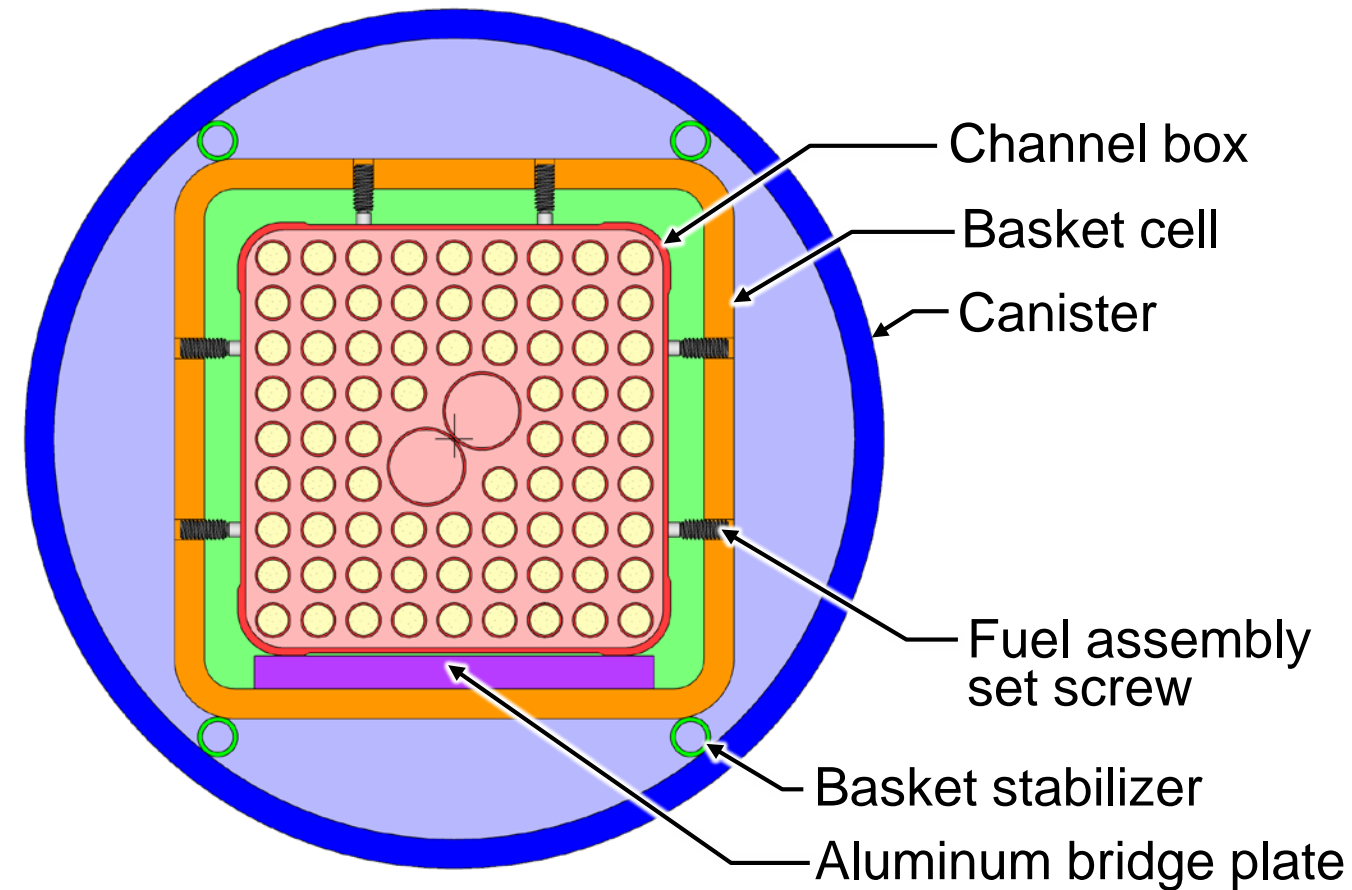

- Modifications made to maintain concentricity and enhance heat conduction
 - Added stabilizers
 - Between channel box and basket
 - Between basket and canister wall
 - Full length to limit convective cells
 - Keep from damaging existing TCs
 - Added aluminum bridge plate
 - Maintain concentricity while reorienting to horizontal configuration
 - Establish conduction pathway between channel box and basket that is seen in commercial storage systems

Assembly Modifications

- Basket stabilizers provide limited conductive paths between the basket and the pressure vessel
 - 1-in length stitch welds at 24-in intervals from the basket bottom to the top
- Stabilizers also meant to limit convective cells



Bottom View

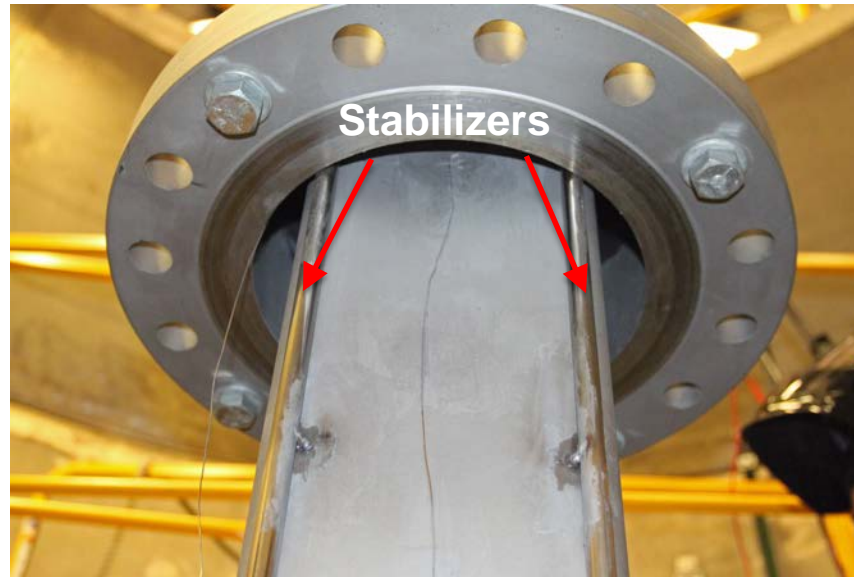

Middle View

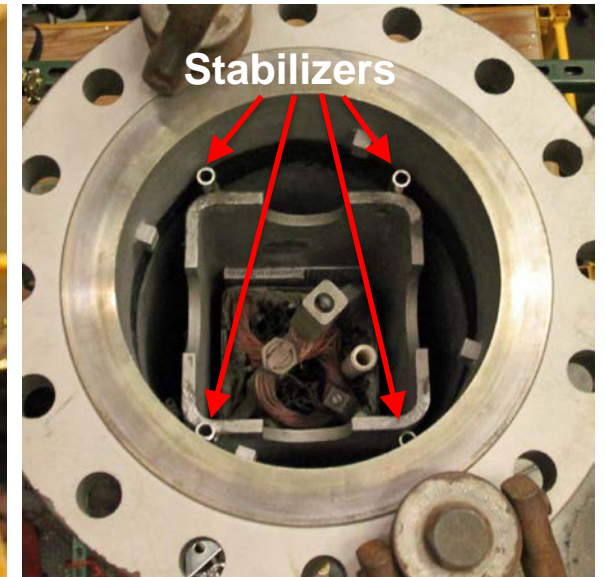

Top View

Facility Transition



- After performing in-vessel modifications
 - HDCS moved from inside of vessel to the 3rd floor
 - Gently rotated assembly to horizontal configuration
- Constructed vault enclosure
 - Inlet and outlets
- Installed additional instrumentation
- Reconnected to DAQ
 - Power control
 - Instrumentation
- Conducted testing



Dimensional Analyses

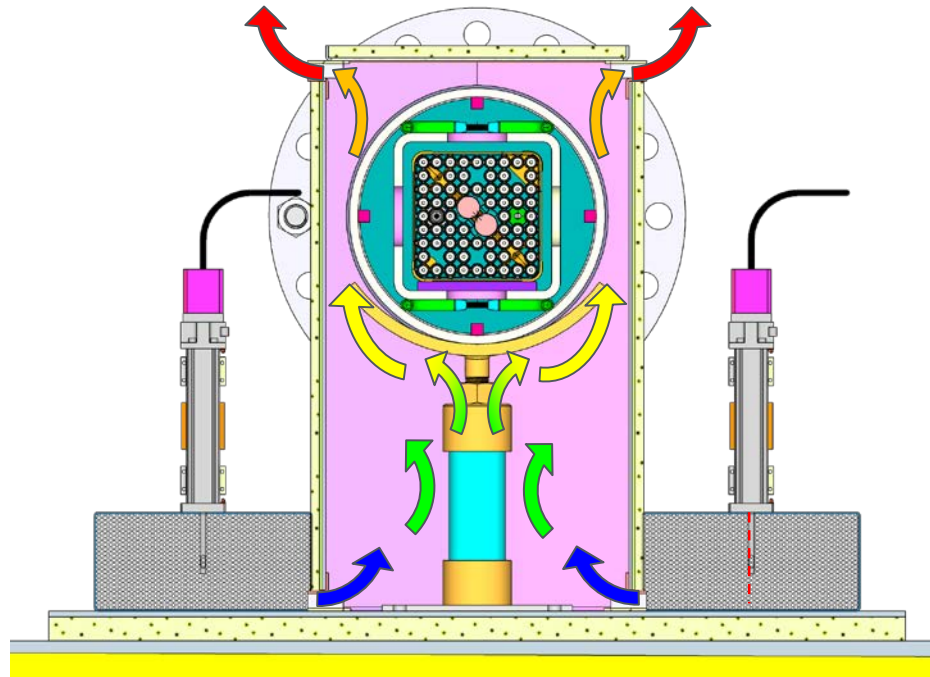
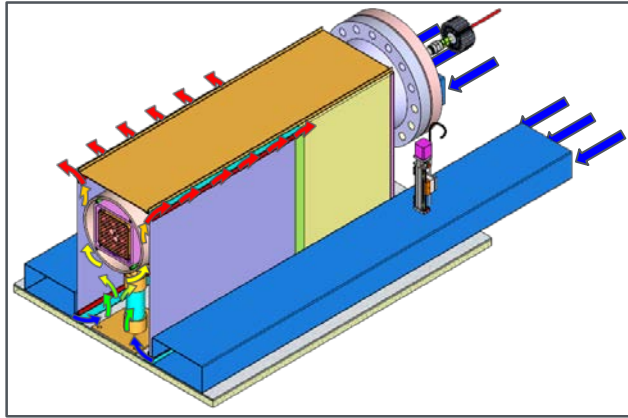

- Internal scaling within fuel maintained by matching prototypic geometry
 - Known scaling distortions
 - Power: Higher surface-area-to-volume
 - Internal heat transfer: Reduced conductivity between structures
- External dimensionless groups may appear dissimilar at first inspection, but...
 - Reynolds: Irregular regime for $270 < Re_D < 5,000$
 - Modified Rayleigh: 3-D wake separation (turbulence) for $Ra_D^* > 3.5 \times 10^9$

Parameter	Horizontal		
	HDCS Low Power	HDCS High Power	Cask
Power (kW)	0.5	5.0	24
Re_D	280	730	2,000
Ra_D^*	1.3E+09	1.3E+10	1.4E+13
Nu_{DH}	30	50	170

HDCS Modeling Validation

HDCS Modeling Validation Exercise

- Results provided for two cases of the overall test matrix
 - 2500 W power, 100 kPa pressure, helium backfill
 - 2500 W power, 100 kPa pressure, air backfill
- Limited data set provided to calibrate models for blind model validation exercise

Fill Gas	Pressure (kPa)	Power (W)
Helium	100	500
	100	1000
	100	2500
	100	5000
	800	500
	800	5000
Air	100	500
	100	1000
	100	2500
	100	5000

HDCS Modeling Validation Exercise

- Comparison metrics for all modelers

Metric	Notes
Peak Cladding Temperature	PCT
PCT location	x, y, z
Air mass flow rate	\dot{m}_{Air}
Axial temperature profile	$T(z)$ at WEU (5 locations)
Transverse x-axis temp. profile	$T(x)$ at $z = 1.219$ m (11 locations)
Transverse y-axis temp. profile	$T(y)$ at $z = 1.829$ m (7 locations)

HDCS Testing Steady-State Results

2500 W, 100 kPa Helium T(z)

Rod Identifier	z (m)	Temperature (K)
DT (PCT)	1.219	559
WEU	0.610	555
	1.219	553
	1.829	548
	2.438	537
	3.658	466
CS	0.152	506
	0.305	534
	0.457	542
	0.610	550
	0.762	552
	0.914	552
	1.067	551
	1.219	554
	1.372	552
	1.549	548
	2.286	542
	2.438	538
	2.616	527
	2.743	523
	2.896	518
	3.023	513
	3.200	509
3.353	503	
GX	1.829	538
	1.981	538
	3.505	482
	3.658	463
	3.962	387

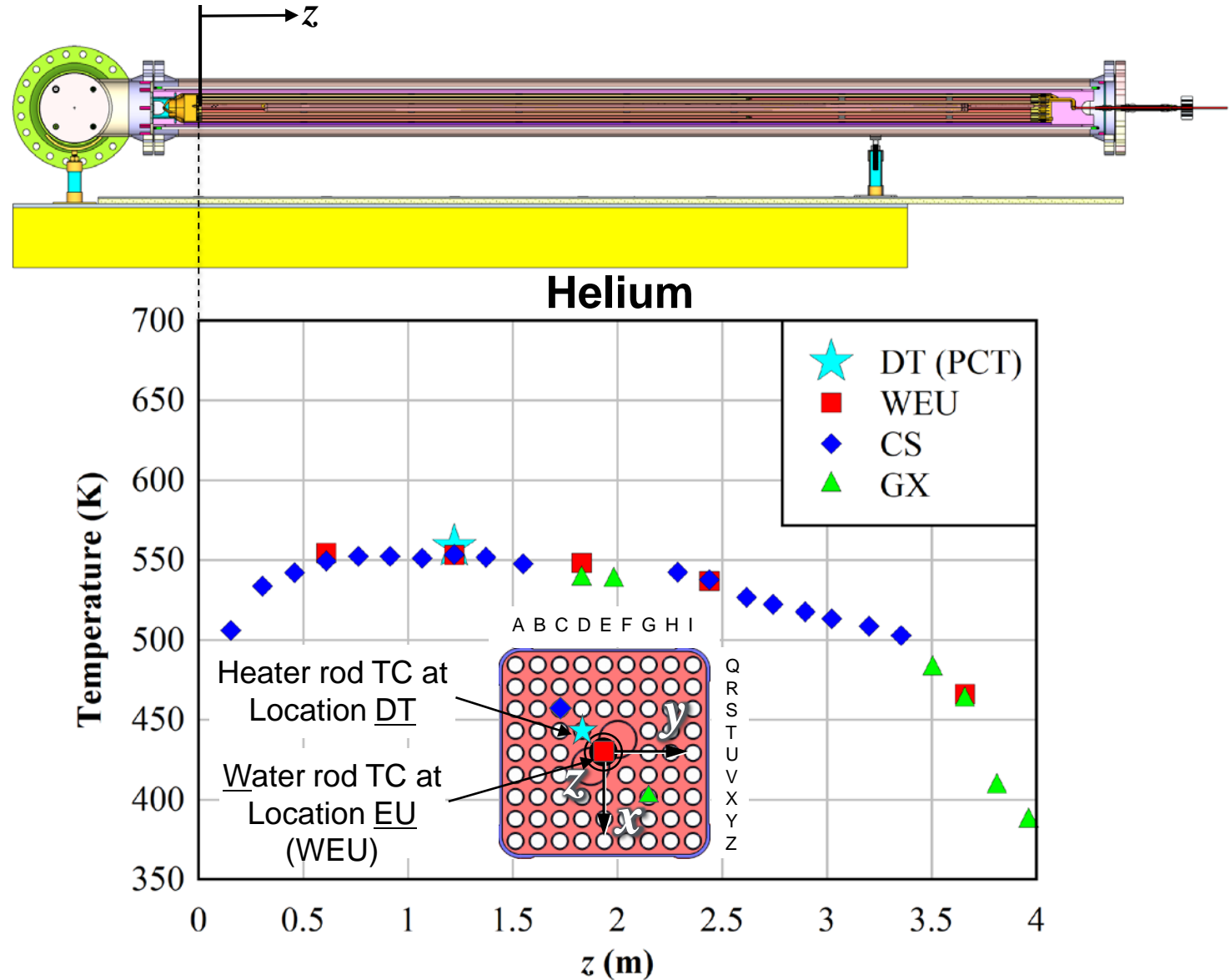

2500 W, 100 kPa Helium $T(z)$

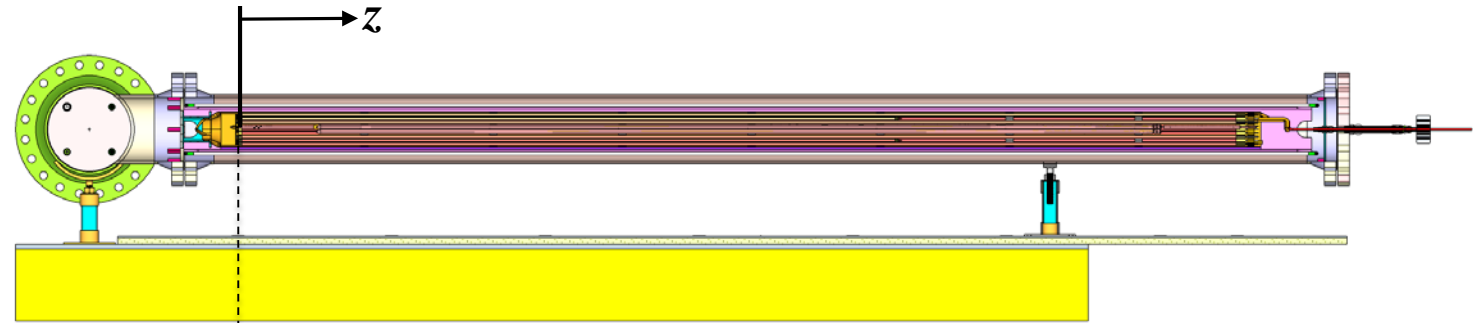

Metric	Notes
Peak Cladding Temperature	PCT
PCT location	x, y, z
Air mass flow rate	\dot{m}_{Air}
Axial temperature profile	$T(z)$ at WEU (5 locations)
Transverse x-axis temp. profile	$T(x)$ at $z = 1.219$ m (11 locations)
Transverse y-axis temp. profile	$T(y)$ at $z = 1.829$ m (7 locations)

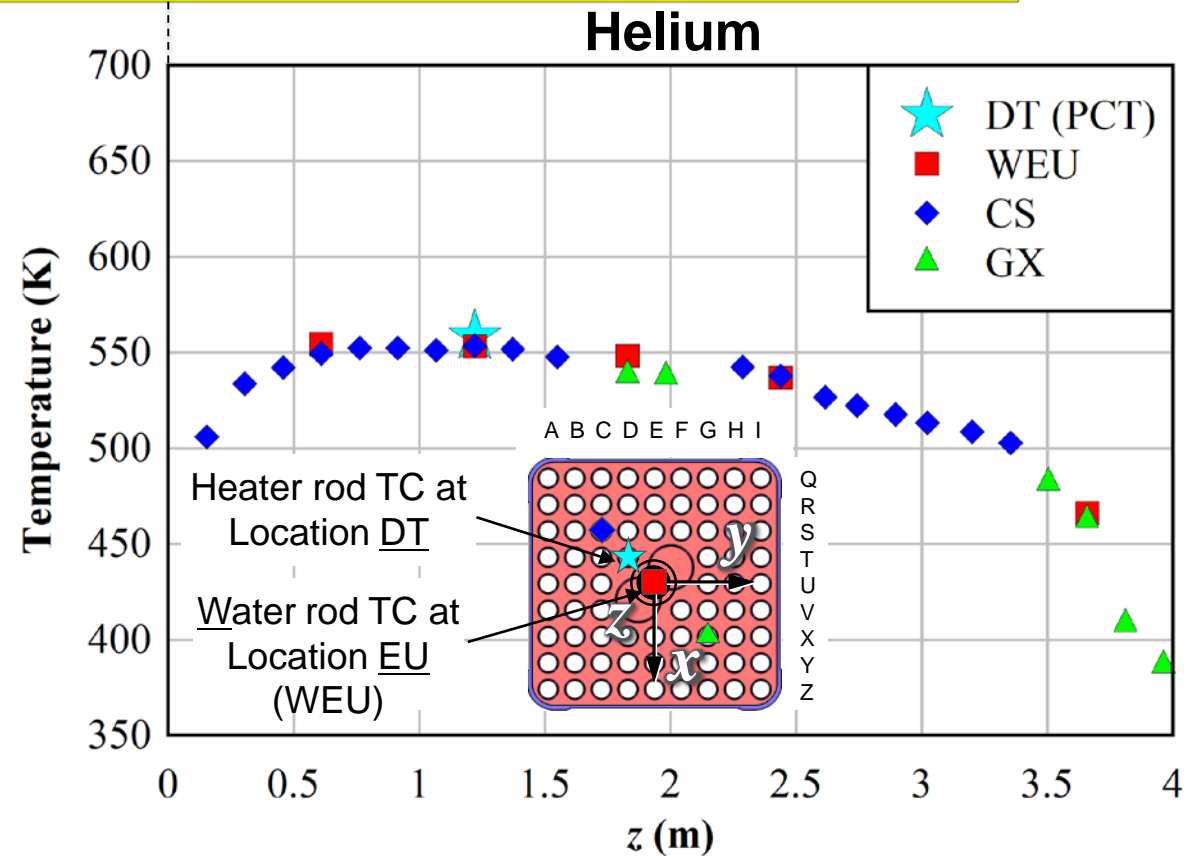

2500 W, 100 kPa Air T(z)

Rod Identifier	z (m)	Temperature (K)
DT (PCT)	0.610	647
WEU	0.610	645
	1.219	637
	1.829	630
	2.438	615
	3.658	527
CS	0.152	603
	0.305	632
	0.457	638
	0.610	641
	0.762	641
	0.914	640
	1.067	638
	1.219	639
	1.372	637
	1.549	633
	2.286	622
	2.438	617
	2.616	603
	2.743	597
	2.896	593
	3.023	590
	3.200	585
	3.353	579
GX	1.829	622
	1.981	622
	3.505	555
	3.658	522
	3.962	431

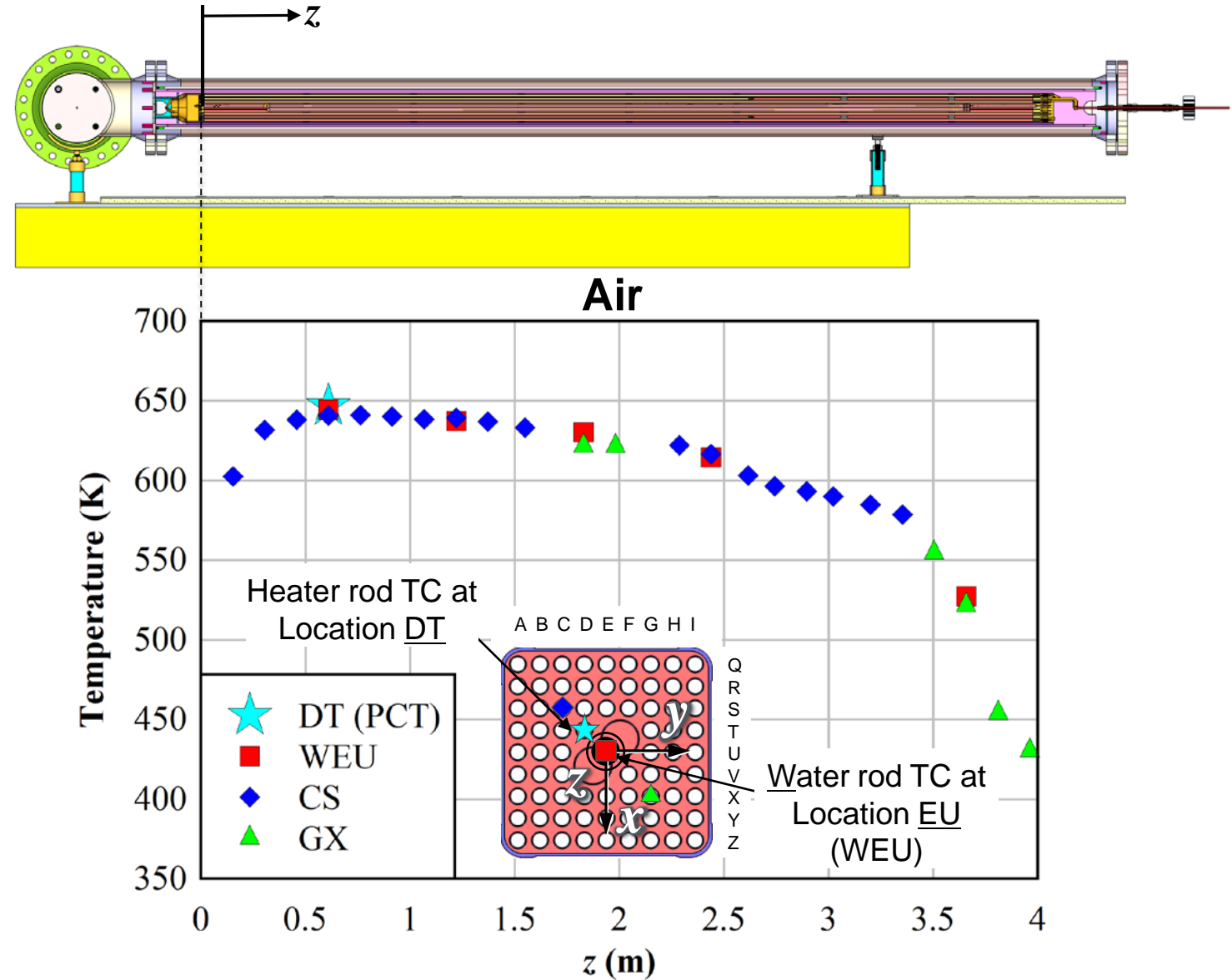

2500 W, 100 kPa Air T(z)

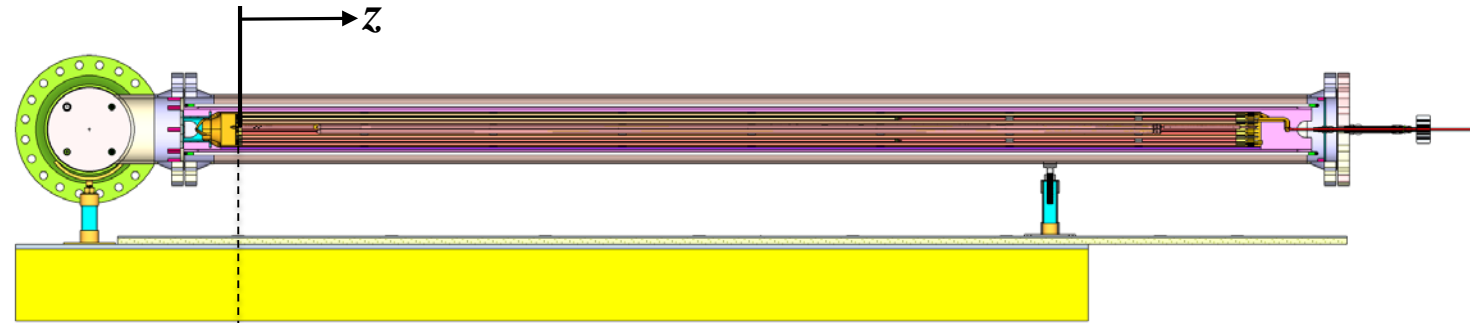

Metric	Notes
Peak Cladding Temperature	PCT
PCT location	x, y, z
Air mass flow rate	\dot{m}_{Air}
Axial temperature profile	$T(z)$ at WEU (5 locations)
Transverse x-axis temp. profile	$T(x)$ at $z = 1.219$ m (11 locations)
Transverse y-axis temp. profile	$T(y)$ at $z = 1.829$ m (7 locations)

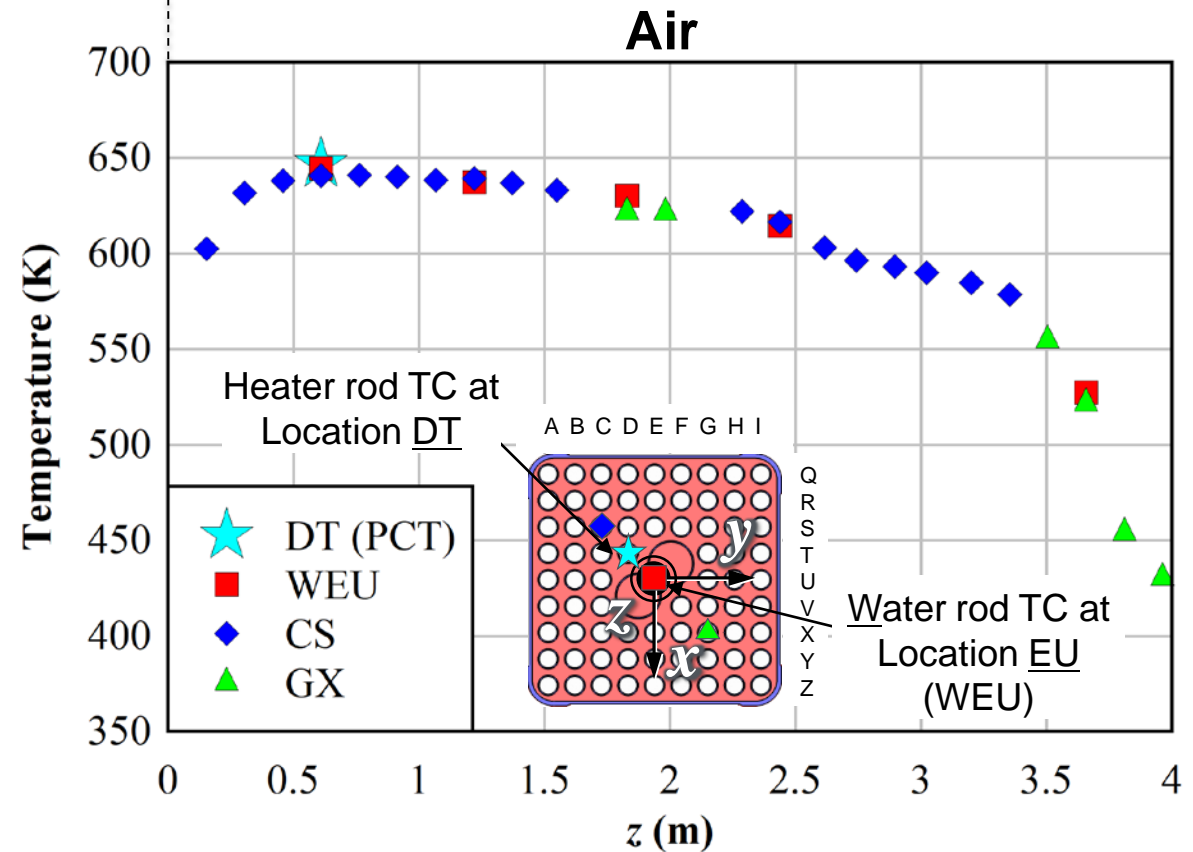

2500 W, 100 kPa Helium T(x) (z = 1.219 m)

Location	x (m)	Temperature (K)
Vault Top	-0.169	368
Pressure Vessel (PV) Top	-0.137	421
Basket Top	-0.090	462
Channel Top	-0.068	506
EQ	-0.057	536
ES	-0.029	558
WEU	0.000	553
Channel Bottom	0.068	477
Basket Bottom	0.090	464
Pressure Vessel (PV) Bottom	0.137	414
Vault Bottom	0.421	323

Metric	Notes
Peak Cladding Temperature	PCT
PCT location	x, y, z
Air mass flow rate	\dot{m}_{Air}
Axial temperature profile	T(z) at WEU (5 locations)
Transverse x-axis temp. profile	T(x) at z = 1.219 m (11 locations)
Transverse y-axis temp. profile	T(y) at z = 1.829 m (7 locations)

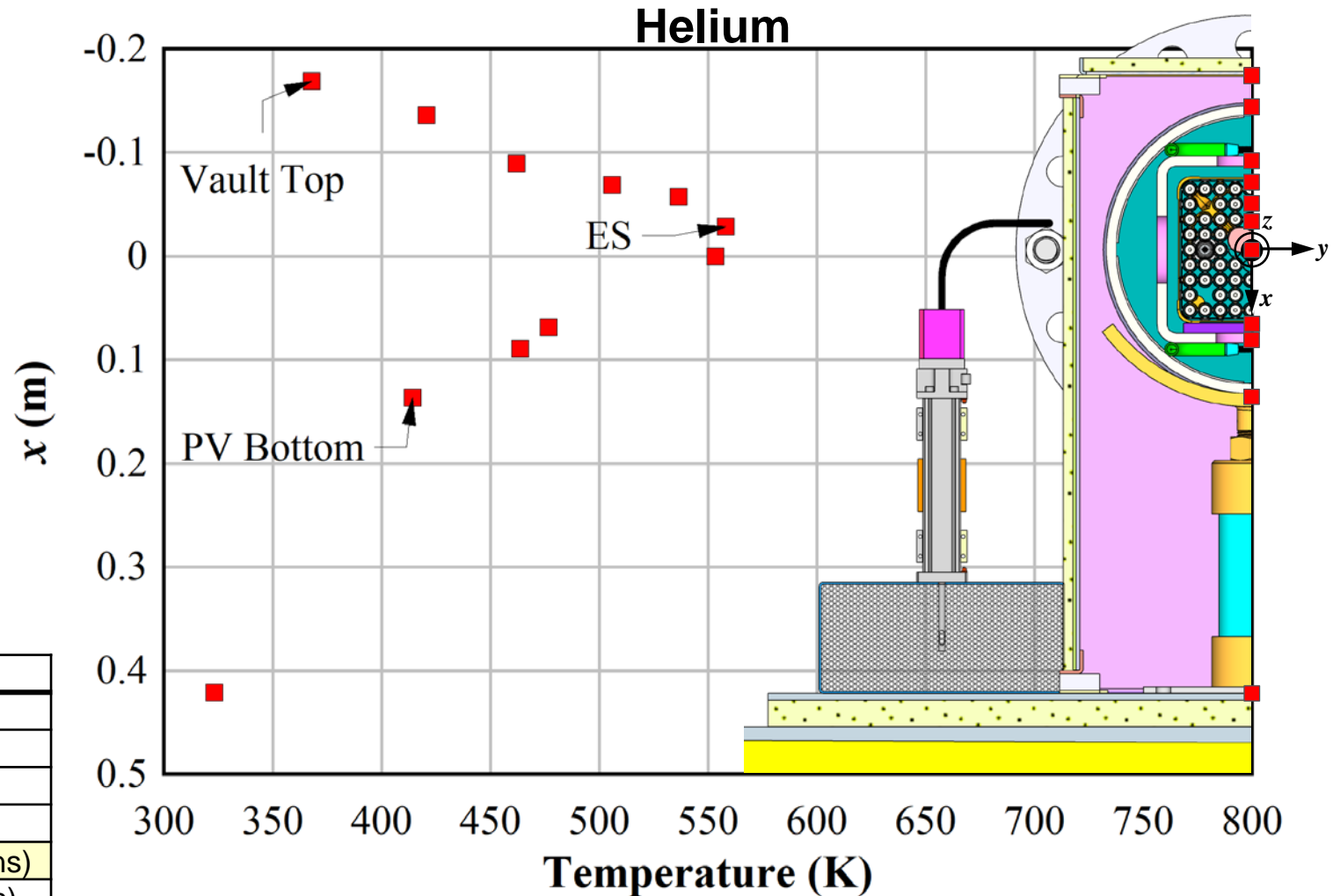

2500 W, 100 kPa Air T(x) (z = 1.219 m)

Location	x (m)	Temperature (K)
Vault Top	-0.169	367
Pressure Vessel (PV) Top	-0.137	420
Basket Top	-0.090	486
Channel Top	-0.068	562
EQ	-0.057	617
ES	-0.029	645
WEU	0.000	637
Channel Bottom	0.068	534
Basket Bottom	0.090	484
Pressure Vessel (PV) Bottom	0.137	408
Vault Bottom	0.421	321

Metric	Notes
Peak Cladding Temperature	PCT
PCT location	x, y, z
Air mass flow rate	\dot{m}_{Air}
Axial temperature profile	T(z) at WEU (5 locations)
Transverse x-axis temp. profile	T(x) at z = 1.219 m (11 locations)
Transverse y-axis temp. profile	T(y) at z = 1.829 m (7 locations)

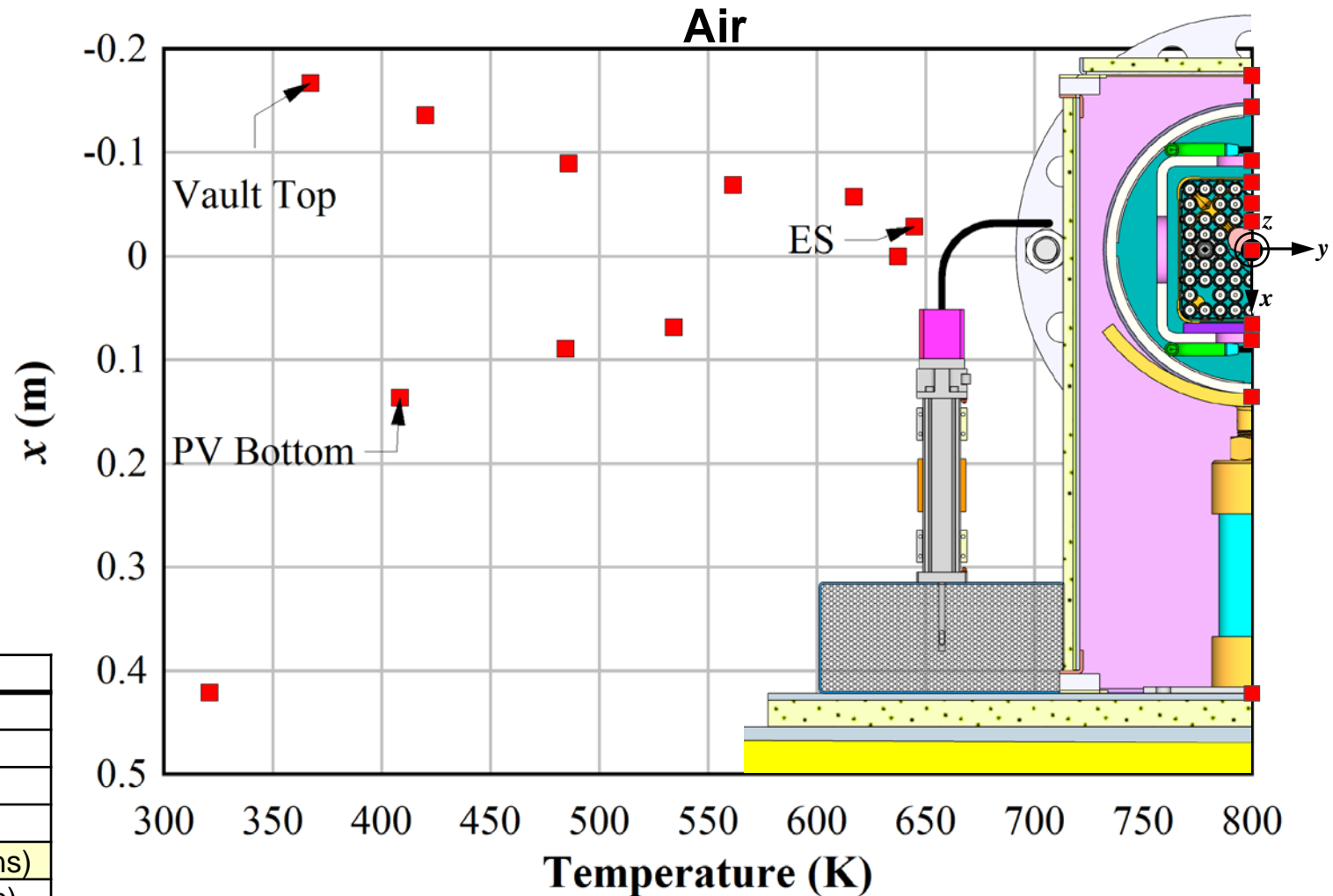

2500 W, 100 kPa Helium T(y) (z = 1.829 m)

Location	y (m)	Temperature (K)
WEU	0.000	548
GU	0.029	550
IU	0.057	532
Channel	0.068	499
Basket	0.089	459
Pressure Vessel (PV)	0.137	416
Vault	0.165	334

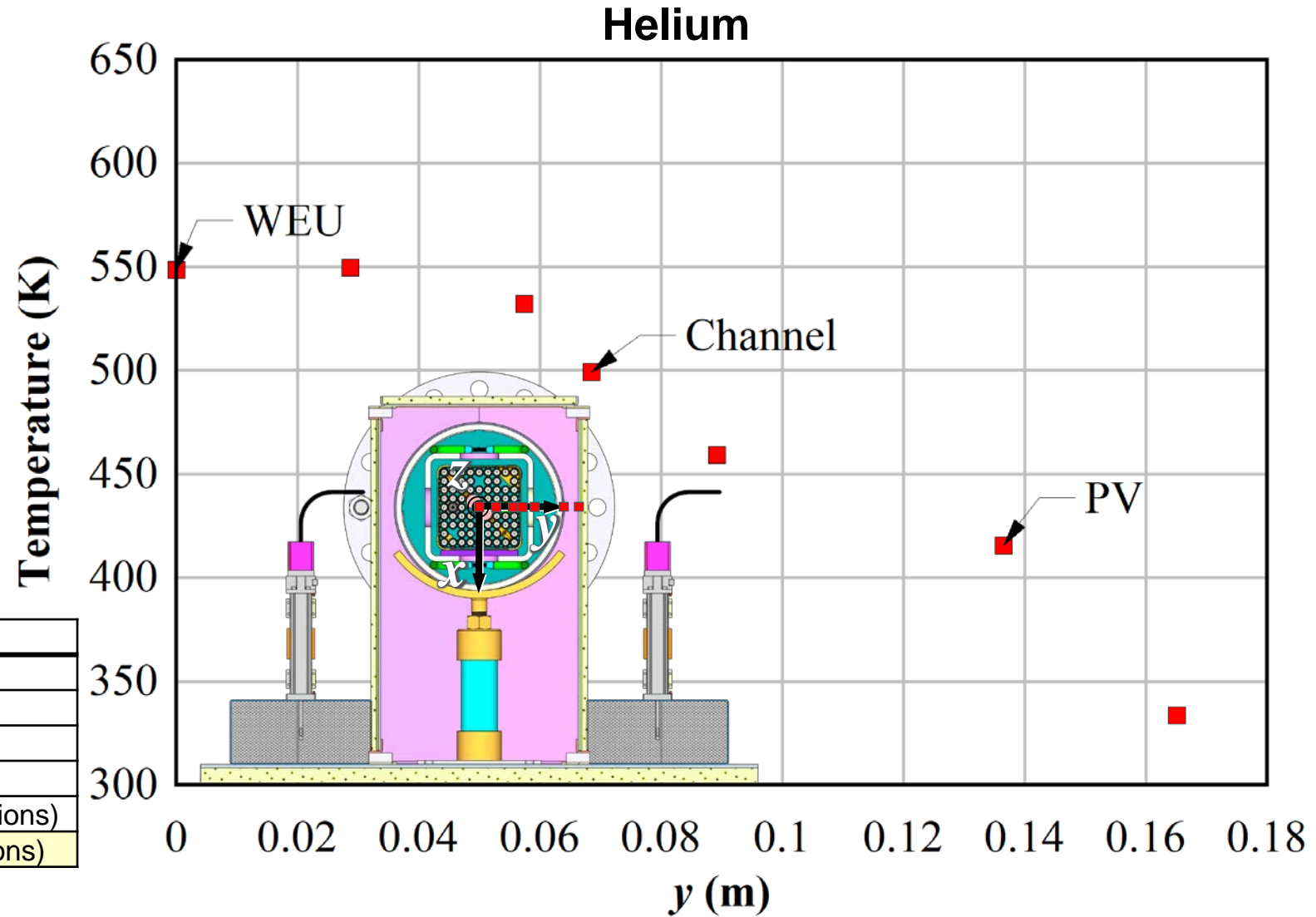

Metric	Notes
Peak Cladding Temperature	PCT
PCT location	x, y, z
Air mass flow rate	\dot{m}_{Air}
Axial temperature profile	T(z) at WEU (5 locations)
Transverse x-axis temp. profile	T(x) at z = 1.219 m (11 locations)
Transverse y-axis temp. profile	T(y) at z = 1.829 m (7 locations)

2500 W, 100 kPa Air T(y) (z = 1.829 m)

Location	y (m)	Temperature (K)
WEU	0.000	630
GU	0.029	634
IU	0.057	607
Channel	0.068	552
Basket	0.089	481
Pressure Vessel (PV)	0.137	414
Vault	0.165	333

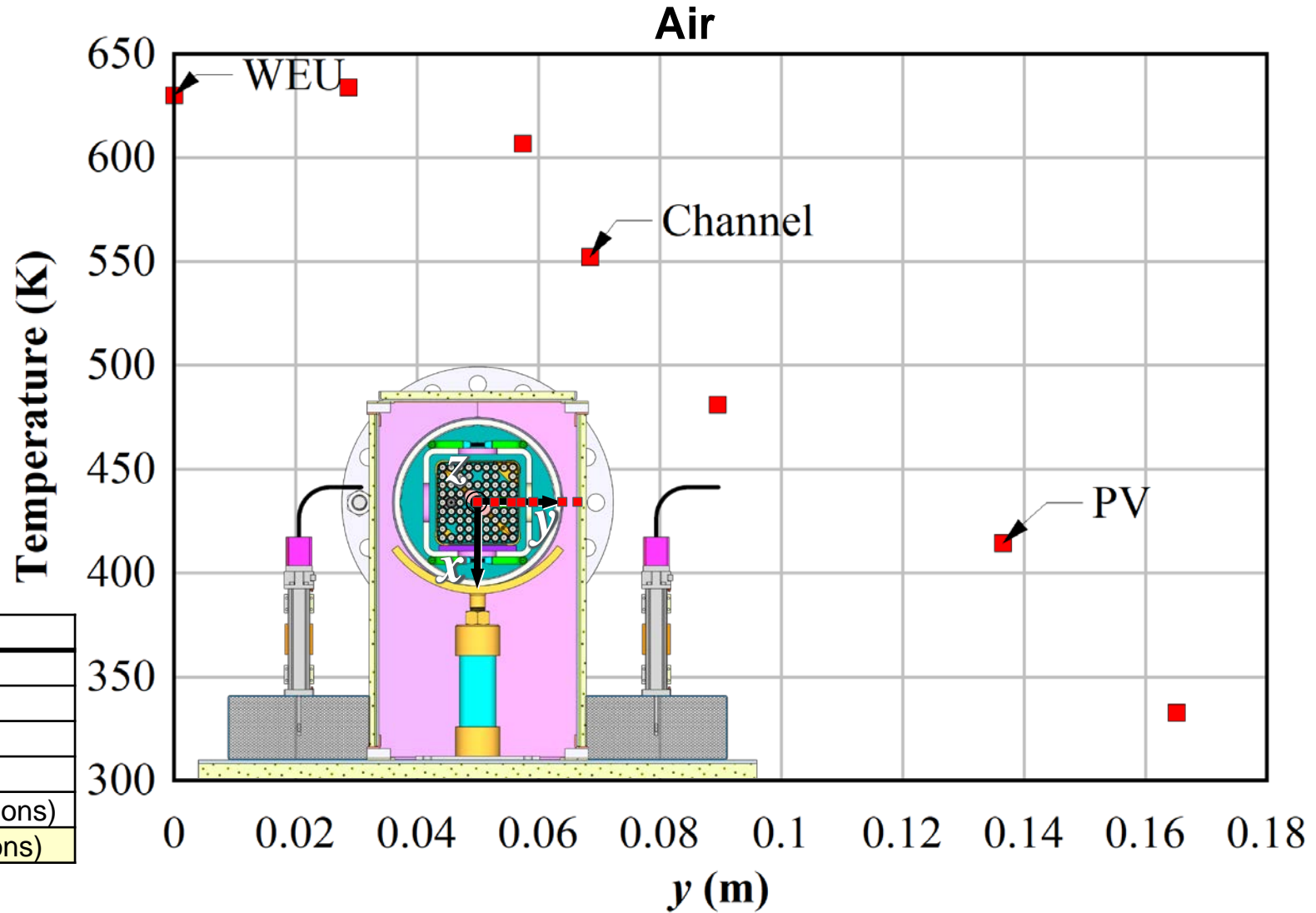

Metric	Notes
Peak Cladding Temperature	PCT
PCT location	x, y, z
Air mass flow rate	\dot{m}_{Air}
Axial temperature profile	T(z) at WEU (5 locations)
Transverse x-axis temp. profile	T(x) at z = 1.219 m (11 locations)
Transverse y-axis temp. profile	T(y) at z = 1.829 m (7 locations)

Transients

PCT

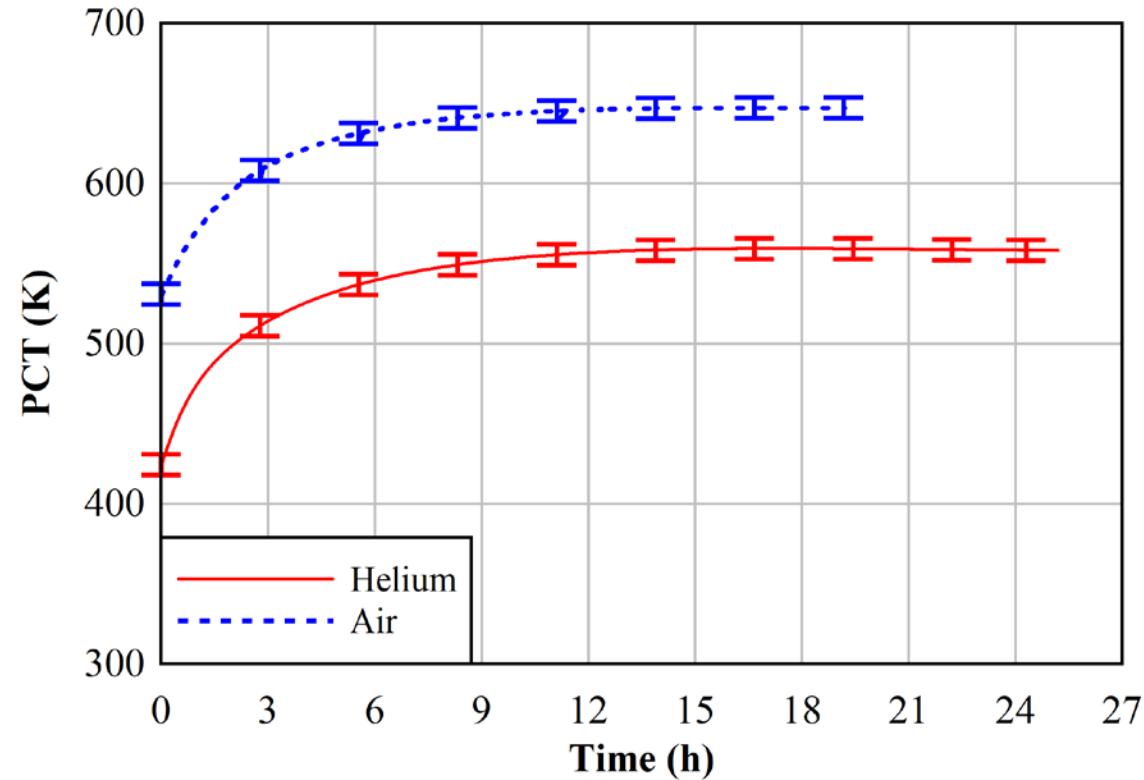

- Expanded Uncertainty: $U_{PCT} = \pm 6.5K$
- Focus is on steady-state region ($dT/dt < 0.3 K/h$)

Air Mass Flow Rate

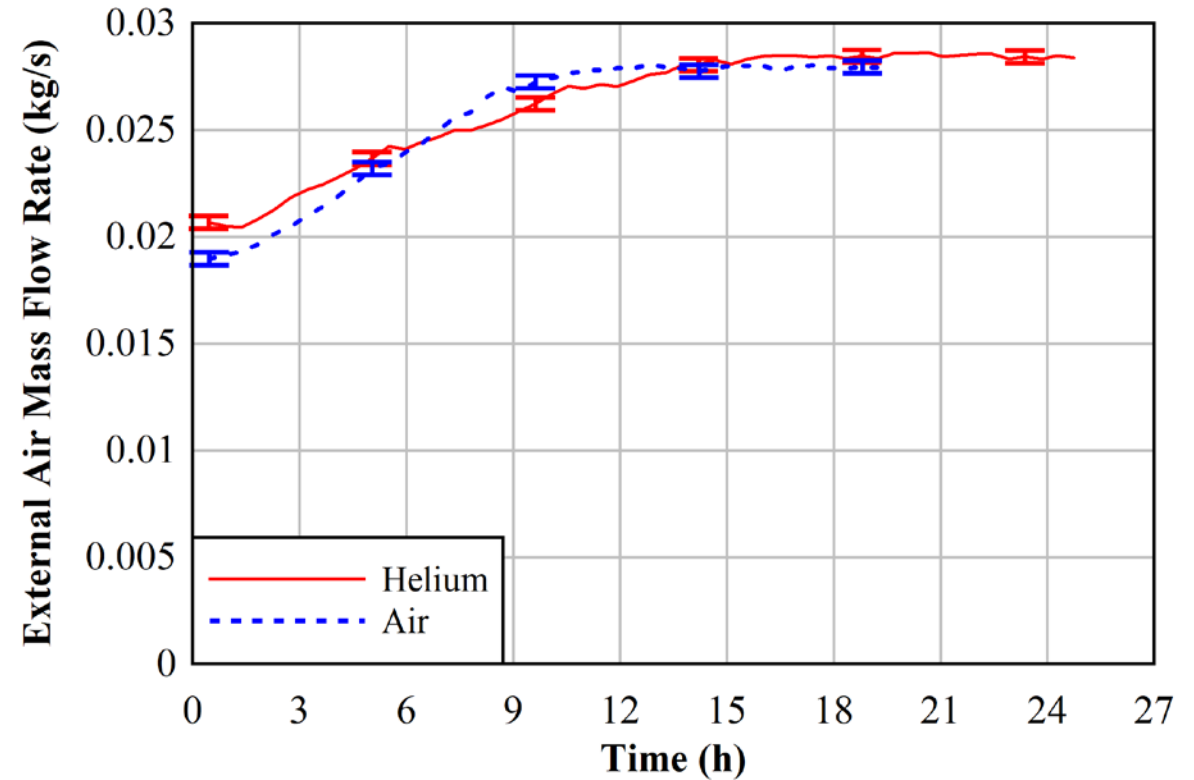

- Expanded Uncertainty: $U_{m, Total} = \pm 3.0 \times 10^{-4} kg/s$
- Total air mass flow rate from 4 inlet ducts calculated from hot wire anemometer profiles

Summary

- Horizontal Dry Cask Simulator testing
 - Construction completed May 2019
 - Test results for limited data sets completed August 2019
 - 2500 W, 100 kPa, helium backfill
 - 2500 W, 100 kPa, air backfill
 - Results reported in “Update on the Thermal Hydraulic Investigations of a Horizontal Dry Cask Simulator” – SAND2019-11688 R
 - Test results for rest of test matrix currently under review
 - Exploration of the repeatability of parameter space planned for FY20
- Applications to blind model validation
 - **Limited data sets provided for model calibration**
 - **Modelers will predict temperatures and air mass flow rates for rest of test runs**

Fill Gas	Pressure (kPa)	Power (W)
Helium	100	500
	100	1000
	100	2500
	100	5000
	800	500
	800	5000
Air	100	500
	100	1000
	100	2500
	100	5000

Vertical Dry Cask Simulator Testing

Aboveground Configuration

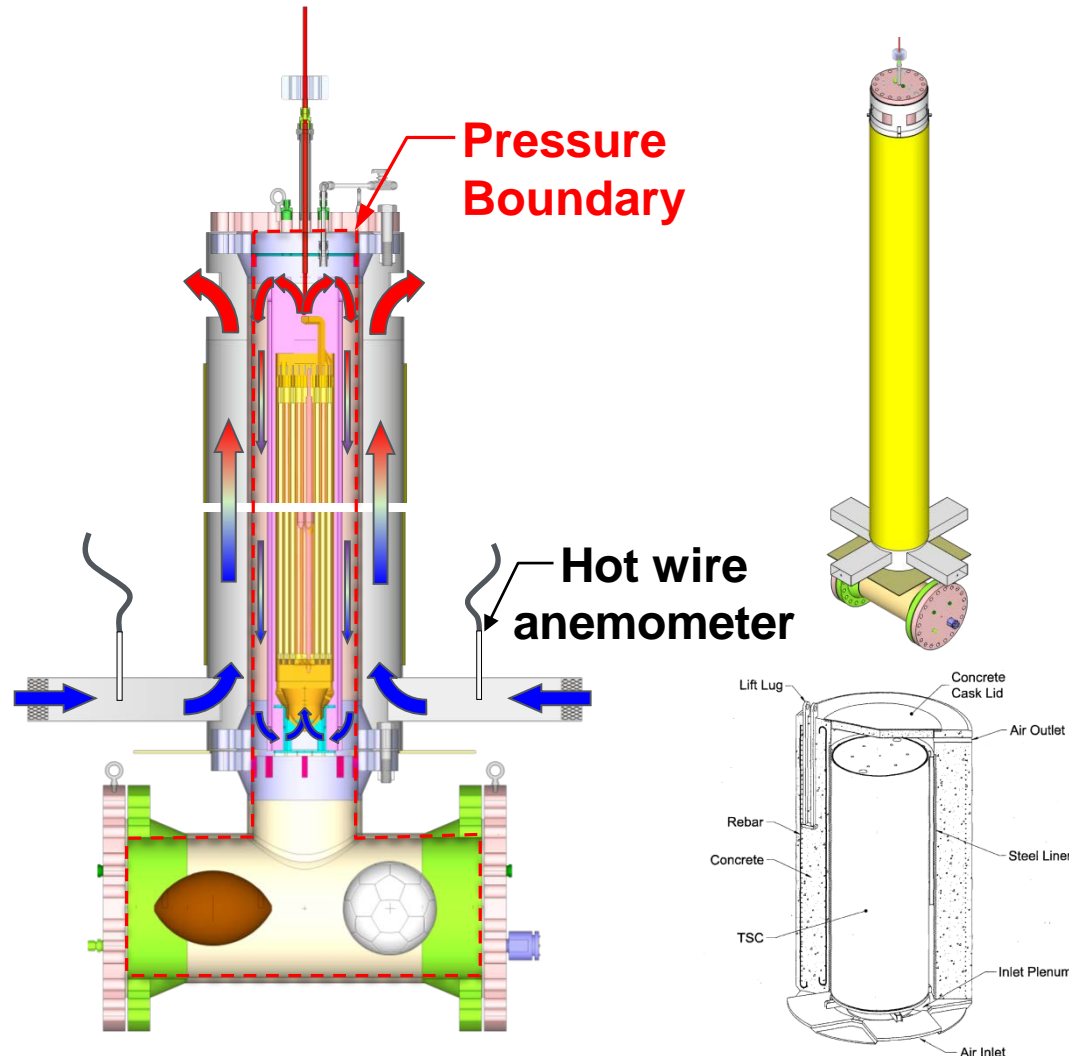

- BWR Dry Cask Simulator (DCS) system capabilities
 - Power: 0.1 – 20 kW
 - Pressure vessel
 - Vessel temperatures up to 400 °C
 - Pressures up to 2,400 kPa
 - ~200 thermocouples throughout system (internal and external)
 - Air velocity measurements at inlets
 - Calculate external mass flow rate
- **Testing Completed August 2016**
 - 14 data sets collected
 - Transient and steady state

Validation Exercise Description

- Compare models and test results for reduced parameter set of available, steady-state data
 - Aboveground configuration only
 - 4 cases – 1) 0.5 kW, 100 kPa 3) 5.0 kW, 100 kPa
 2) 0.5 kW, 800 kPa 4) 5.0 kW, 800 kPa
- 6 model submissions
 - 5 computational fluid dynamics (CFD) models, 1 subchannel model
 - Three models use porous media representation of the fuel region
 - Two models explicitly represent fuel geometry
 - One model represents the fuel as quasi-3D rods
- Temperature comparisons throughout
 - Fuel (minimum, average, and maximum) as function of height
 - Channel box, basket, canister (pressure vessel), and overpack (shell) as function of height
 - Transverse temperature profiles at PCT locations

Model Descriptions

- The 6 models can be categorized by:
 - Code type
 - Fuel representation
 - Cross-sectional symmetry

Modeling Contributor	Code Type	Fuel Representation	Cross-Sectional Symmetry
NRC	CFD	Porous Media	1/4
PNNL	CFD	Explicit	1/4
PNNL	CFD	Porous Media	1/4
PNNL	Subchannel	Quasi-3D Rods	Full
CIEMAT	CFD	Porous Media	1/8
ENUSA	CFD	Explicit	1/2

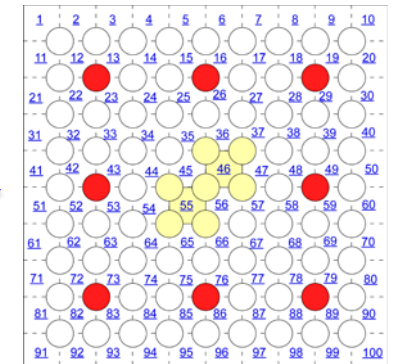
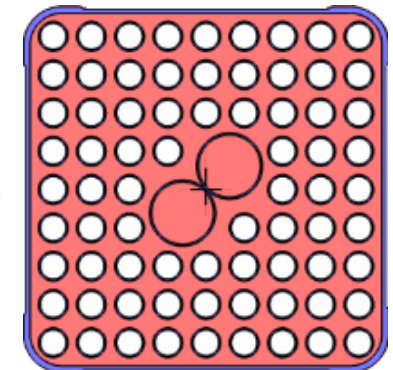
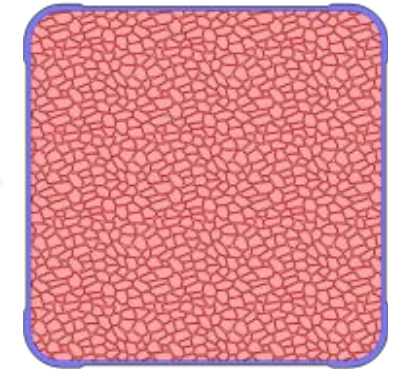

Fuel Comparisons (0.5 kW, 100 kPa)

Minimum Fuel

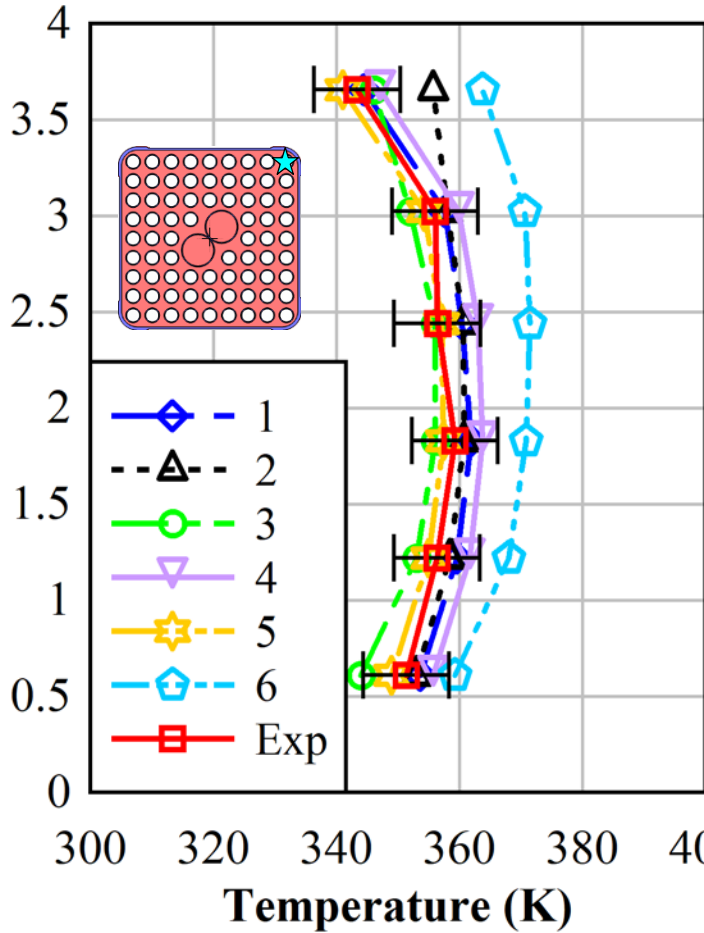

Average Fuel

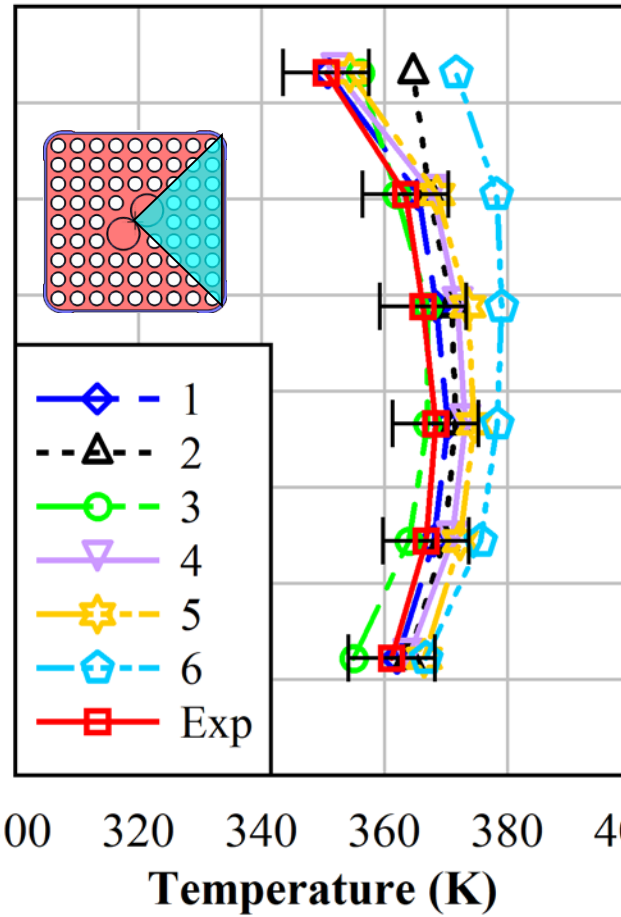

Maximum Fuel

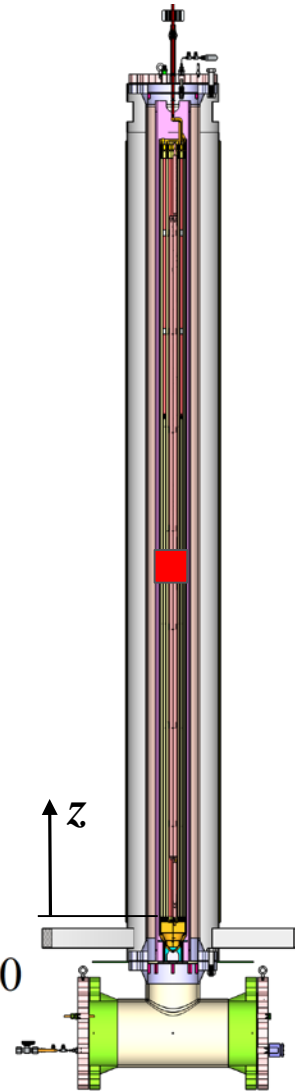
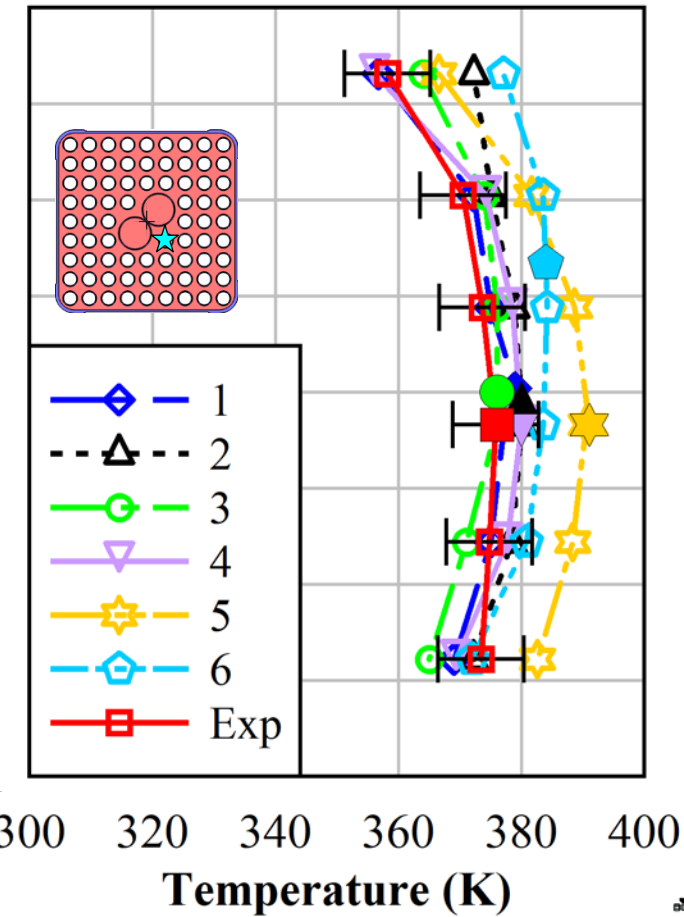

Fuel Comparisons (5 kW, 800 kPa)

